









































SOMETHING IS DIFFERENT
LOOK INSIDE



INHALTSVERZEICHNIS CONTENTS

Puffer <i>Buffer</i>		Seite <i>Page</i>	Tüllen <i>Grommets</i>		Seite <i>Page</i>
Anschraubpuffer <i>Screw-Type Buffer</i>		5	Kabeldurchführungen mit Radius <i>Cable Grommets with Radius</i>		41-44
Puffer mit Zapfen <i>Buffer With Pin</i>		6-14	Kabeldurchführungen ohne Radius <i>Cable Grommets without Radius</i>		45-46
Puffer ohne Zapfen <i>Buffer Without Pin</i>		15-18	Kabeldurchführungen Sonderformen <i>Cable Grommets Special Form</i>		47
Puffer Sonderform <i>Buffer Special Form</i>		19	Kabeldurchführungen U-Form <i>Cable Grommets U-Shape</i>		48
Softpuffer - Form 1 <i>Softbuffer - Shape 1</i>		20	Knickschutztüllen <i>Bend Relief Grommets</i>		49
Softpuffer - Form 2 <i>Softbuffer - Shape 2</i>		21	Langlochtülle <i>Oblong Grommet</i>		50
Softpuffer - Form 3 <i>Softbuffer - Shape 3</i>		22	SNAP® Easy Tight <i>SNAP® Easy-Tight</i>		51-52
Softpuffer - Form 4 <i>Softbuffer - Shape 4</i>		23	SNAP® Metric Light <i>SNAP® Metric Light</i>		53-54
Softpuffer - Form 5 <i>Softbuffer - Shape 5</i>		24	SNAP® Metric Light Open <i>SNAP® Metric Light Open</i>		55-56
Gummistopfen <i>Rubber Stops</i>		25-28	SNAP® PG <i>SNAP® PG</i>		57
Stopfen <i>Plugs</i>		Seite <i>Page</i>	SNAP® PG Open <i>SNAP® PG Open</i>		58
Karosseriestopfen <i>Blanking Plug</i>		30-31	SNAP® Metric <i>SNAP® Metric</i>		59
Lamellenstopfen <i>Lamellar Plugs</i>		32-33	SNAP® Metric Open <i>SNAP® Metric Open</i>		60
Steckfuß <i>Rubber Stopper</i>		34	SNAP® Multiflex <i>SNAP® Multiflex</i>		61
Tüllenpuffer <i>Rubber Bumper</i>		35	SNAP® Multigate <i>SNAP® Multigate</i>		62
Abdeckkappen <i>Masking Caps</i>		36	SNAP® DNG <i>SNAP® DNG</i>		63
Tüllen <i>Grommets</i>		Seite <i>Page</i>	Kabeldurchführungen Sonderformen <i>Cable Grommets Special Form</i>		64
Kabeldurchführung mit einseitigem Bund <i>Cable Grommets with one-sided Collar</i>		38	Kabeldurchführungen mit reduziertem Durchgang <i>Cable Grommets Special Form</i>		65
Kabeldurchführung mit innenliegender Dichtlippe <i>Cable Grommet with inside Sealing Lip</i>		39	Verschlussstüllen - Form 1 <i>Sealing (Blanking) Plug - Shape 1</i>		66
Kabeldurchführungen mit asymmetrischem Bund <i>Cable Grommets with asymmetric Collar</i>		40	Verschlussstüllen - Form 2 <i>Sealing (Blanking) Plug - Shape 2</i>		67
			Verschlussstüllen - Form 3 <i>Sealing (Blanking) Plug - Shape 3</i>		68



PUFFER
BUFFER



IHR PARTNER FÜR GUMMIKLEINTEILE

Die A. Vogt GmbH & Co. KG besteht seit 1946 und hat ihren Sitz in Arnsberg, Nordrhein-Westfalen. Das Unternehmen ist seit drei Generationen im Familienbesitz. Unser Produktionsprogramm besteht aus standardisierten Gummiformteilen sowie kundenspezifischen Gum-

miformteilen aus allen gängigen Elastomeren. Namhafte Hersteller der Automobil- und Elektroindustrie vertrauen ebenso auf Produkte von GUMMIVOGT wie viele weitere Kunden, insbesondere im Anlagen- und Maschinenbau. Unser Unternehmen verfügt über einen hauseigenen For-

men-, Werkzeug- und Anlagenbau. Das macht uns ausgesprochen flexibel für kundenspezifische Produktionswünsche und sichert die durchgängig höchste Qualität aller Produkte.

YOUR PARTNER FOR SMALL RUBBER PARTS

A. Vogt GmbH & Co. KG has existed since 1946 and is based in the German town of Arnsberg, North Rhine-Westphalia. The company has been family-owned for three generations. Our product portfolio consists of standardised moulded rubber parts

as well as customer-specific moulded rubber parts made of all common elastomers. Well-known manufacturers in the automotive and electrical industries rely on GUMMIVOGT products, as do many other customers, especially in plant construction and

mechanical engineering. Our company has its own in-house mould, tool and plant construction department. This makes us extremely flexible for customer-specific production requirements and consistently ensures the highest quality of all products.



ANSCHRAUBPUFFER
SCREW-TYPE BUFFER

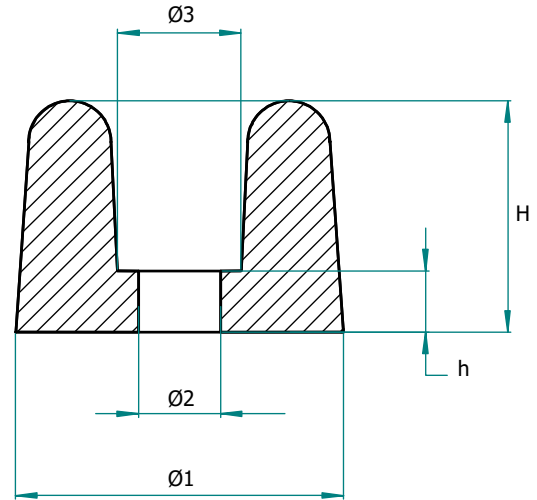

Artikel Nr. <i>Part no.</i>	Gesamt Ø <i>Total Ø</i>	Sockelhöhe <i>Pedestal height</i>	Loch Ø <i>Hole Ø</i>	Gesamthöhe <i>Total height</i>	Innen Ø <i>Inner Ø</i>	Material <i>Material</i>	
	Ø1	h	Ø2	H	Ø3		
1743	29,5	10,0	4,0	20,0	7,8	EB	
1744	22,0	4,5	5,0	11,0	9,7	NR-SBR	
1745	14,6	3,0	5,2	8,5	10,0	NR-SBR	
1746	13,5	5,0	3,0	9,5	6,7	NR-SBR	
1747	18,0	4,5	4,6	11,0	9,3	NR-SBR	

Information:

EB = EPDM, schwarz ; NR-SBR = NR-SBR, schwarz

Toleranzen nach (DIN ISO 3302, Teil 2 M2F)
Irrtum vorbehalten

Information:

EB = EPDM, black ; NR-SBR = NR-SBR, black

General measuring tolerances (DIN ISO 3302, section 2 M2F)
Errors excepted



PUFFER MIT ZAPFEN
BUFFER WITH PIN

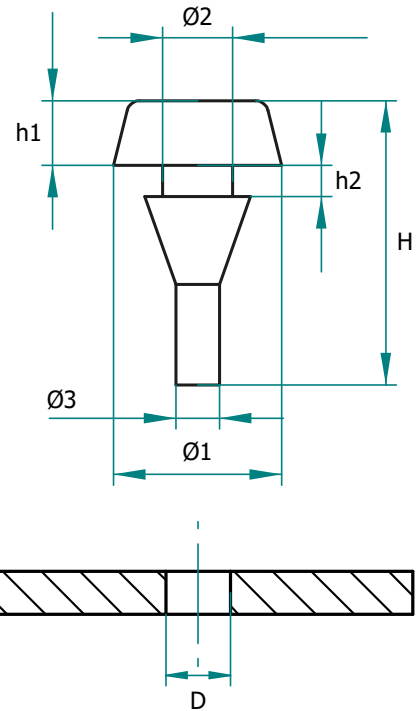

Artikel Nr. <i>Part no.</i>	Kopf Ø <i>Head Ø</i>	Kopfhöhe <i>Head height</i>	Hals Ø <i>Neck Ø</i>	Spalt <i>Gap</i>	Zapfen Ø <i>Tap Ø</i>	Gesamthöhe <i>Total height</i>	Material <i>Material</i>	
	Ø1	h1	Ø2	h2	Ø3	H		
1240	7,8	5,5	4,0	2,5	3,0	18,5	EB	
1241	8,0	6,0	4,0	3,0	3,4	19,0	EB	
1242	4,7	2,2	2,3	0,7	2,0	9,3	EB	
1243	6,0	3,1	2,7	0,7	2,0	10,3	EB	
1245	4,8	2,4	2,8	1,2	2,0	8,2	EB	
1249	8,0	5,3	4,0	2,4	2,9	17,9	EB	
1250	8,0	3,0	3,2	1,5	2,0	13,3	EB	

Information:
EB = EPDM, schwarz

Toleranzen nach (DIN ISO 3302, Teil 2 M2F)
Irrtum vorbehalten

Information:
EB = EPDM, black

General measuring tolerances (DIN ISO 3302, section 2 M2F)
Errors excepted



PUFFER MIT ZAPFEN
BUFFER WITH PIN

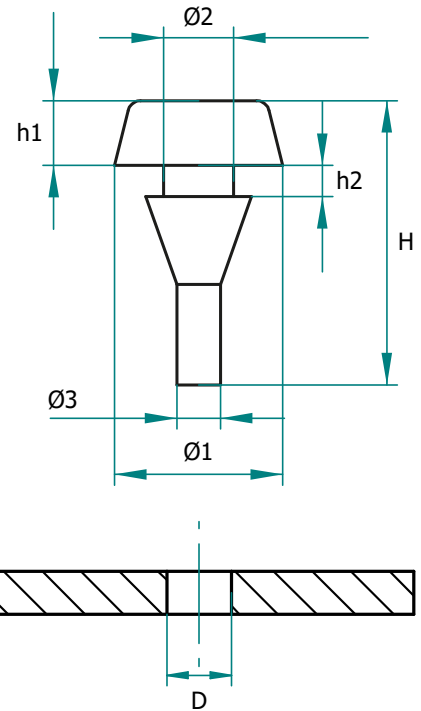

Artikel Nr. <i>Part no.</i>	Kopf Ø <i>Head Ø</i>	Kopfhöhe <i>Head height</i>	Hals Ø <i>Neck Ø</i>	Spalt <i>Gap</i>	Zapfen Ø <i>Tap Ø</i>	Gesamthöhe <i>Total height</i>	Material <i>Material</i>	
	Ø1	h1	Ø2	h2	Ø3	H		
1252	4,8	4,0	2,8	1,2	2,0	11,0	EB	
1253	5,5	5,0	2,5	2,5	1,8	15,0	EB	
1256	7,8	5,5	4,0	2,5	3,0	37,8	EB	
1258	7,0	3,5	3,7	1,6	3,2	10,2	EB	
1259	10,3	8,4	3,7	0,6	2,5	17,3	EB	
1260	8,0	5,0	3,2	1,5	2,1	16,0	EB	
1261	10,3	7,2	3,7	0,7	2,5	16,2	EB	

Information:

EB = EPDM, schwarz

Toleranzen nach (DIN ISO 3302, Teil 2 M2F)
Irrtum vorbehalten

Information:

EB = EPDM, black

General measuring tolerances (DIN ISO 3302, section 2 M2F)
Errors excepted



PUFFER MIT ZAPFEN
BUFFER WITH PIN

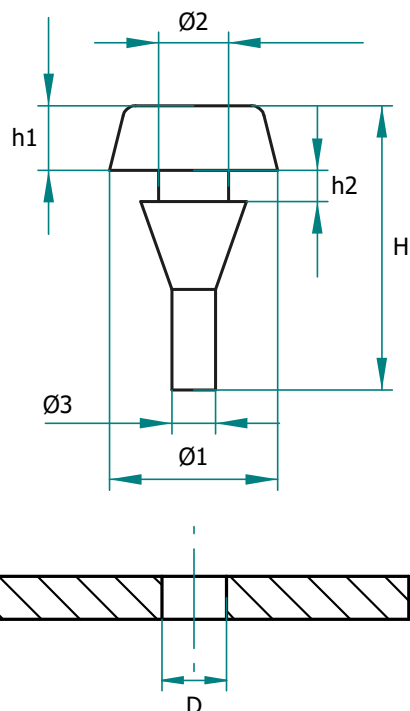

Artikel Nr. <i>Part no.</i>	Kopf Ø <i>Head Ø</i>	Kopfhöhe <i>Head height</i>	Hals Ø <i>Neck Ø</i>	Spalt <i>Gap</i>	Zapfen Ø <i>Tap Ø</i>	Gesamthöhe <i>Total height</i>	Material <i>Material</i>	
	Ø1	h1	Ø2	h2	Ø3	H		
1262	6,0	4,1	2,5	1,5	2,0	10,5	EB	
1264	10,3	5,0	3,7	1,5	2,6	14,9	EB	
1265	4,0	2,4	1,5	1,2	1,2	7,5	EB	
1266	6,0	1,0	3,0	3,0	2,5	10,4	EB	
1267	5,0	1,5	2,8	1,2	2,0	13,3	EB	
1268	7,0	7,0	2,8	2,4	2,1	18,1	EB	
1269	8,0	7,0	4,0	2,5	3,0	19,7	EB	

Information:

EB = EPDM, schwarz

Toleranzen nach (DIN ISO 3302, Teil 2 M2F)
Irrtum vorbehalten

Information:

EB = EPDM, black

General measuring tolerances (DIN ISO 3302, section 2 M2F)
Errors excepted



PUFFER MIT ZAPFEN
BUFFER WITH PIN

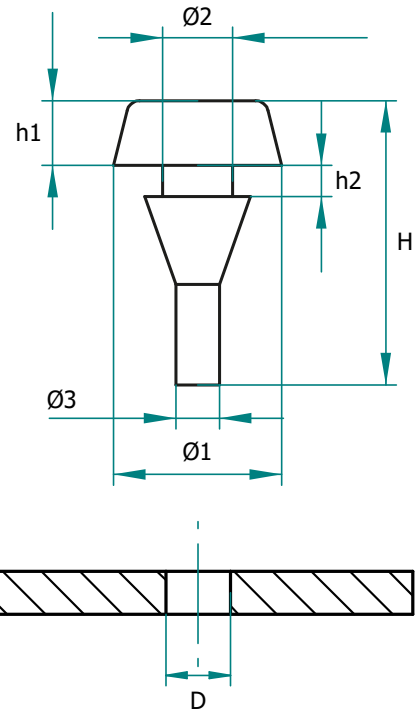

Artikel Nr. <i>Part no.</i>	Kopf Ø <i>Head Ø</i>	Kopfhöhe <i>Head height</i>	Hals Ø <i>Neck Ø</i>	Spalt <i>Gap</i>	Zapfen Ø <i>Tap Ø</i>	Gesamthöhe <i>Total height</i>	Material <i>Material</i>	
	Ø1	h1	Ø2	h2	Ø3	H		
1270	8,0	4,8	4,0	2,5	3,0	17,5	EB	
1271	5,0	1,5	2,8	1,2	2,0	7,3	EB	
1272	5,0	1,8	2,8	1,5	2,0	13,3	EB	
1273	8,7	5,0	3,6	1,4	2,6	15,1	EB	
1274	10,0	6,8	4,0	1,4	3,0	18,3	EB	
1275	7,0	7,0	3,5	2,5	3,0	17,0	EB	
1276	5,0	1,8	3,0	1,5	2,0	13,3	EB	

Information:
EB = EPDM, schwarz

Toleranzen nach (DIN ISO 3302, Teil 2 M2F)
Irrtum vorbehalten

Information:
EB = EPDM, black

General measuring tolerances (DIN ISO 3302, section 2 M2F)
Errors excepted



PUFFER MIT ZAPFEN
BUFFER WITH PIN

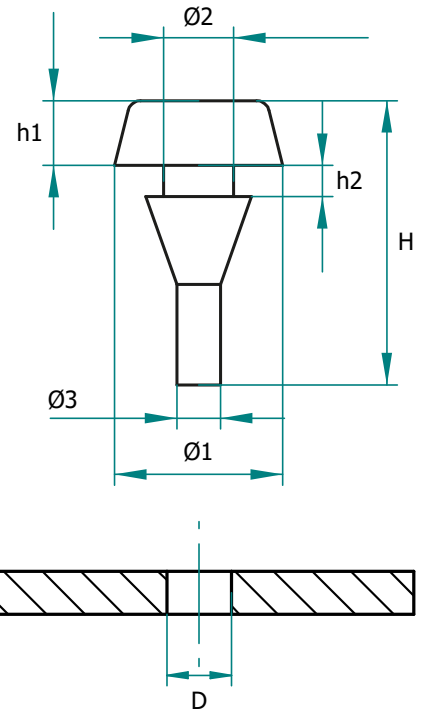

Artikel Nr. <i>Part no.</i>	Kopf Ø <i>Head Ø</i>	Kopfhöhe <i>Head height</i>	Hals Ø <i>Neck Ø</i>	Spalt <i>Gap</i>	Zapfen Ø <i>Tap Ø</i>	Gesamthöhe <i>Total height</i>	Material <i>Material</i>	
	Ø1	h1	Ø2	h2	Ø3	H		
1277	7,0	3,5	3,7	3,0	3,2	11,5	EB	
1278	6,5	4,7	2,3	0,6	2,0	12,2	EB	
1281	8,0	7,0	4,0	2,0	3,0	16,7	EB	
1282	6,7	6,0	3,2	2,0	3,0	16,1	EB	
1283	8,0	2,0	4,0	2,5	3,0	14,7	EB	
1284	8,0	3,2	3,5	1,2	2,4	9,7	EB	
1285	7,0	3,2	3,8	1,0	2,0	9,3	EB	

Information:

EB = EPDM, schwarz

Toleranzen nach (DIN ISO 3302, Teil 2 M2F)
Irrtum vorbehalten

Information:

EB = EPDM, black

General measuring tolerances (DIN ISO 3302, section 2 M2F)
Errors excepted



PUFFER MIT ZAPFEN
BUFFER WITH PIN

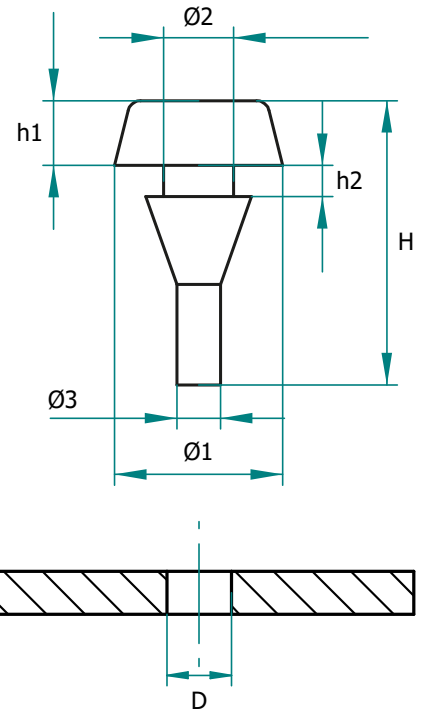

Artikel Nr. <i>Part no.</i>	Kopf Ø <i>Head Ø</i>	Kopfhöhe <i>Head height</i>	Hals Ø <i>Neck Ø</i>	Spalt <i>Gap</i>	Zapfen Ø <i>Tap Ø</i>	Gesamthöhe <i>Total height</i>	Material <i>Material</i>	
	Ø1	h1	Ø2	h2	Ø3	H		
1286	3,0	1,0	1,5	2,0	1,0	7,0	EB	
1287	7,8	2,3	3,5	1,0	2,2	8,8	EB	
1288	8,0	4,0	3,5	1,0	2,3	11,0	EB	
1290	7,0	3,0	3,7	3,0	3,1	12,7	EB	
1291	7,0	3,2	3,8	1,0	2,0	15,5	EB	
1295	7,0	2,5	3,7	3,0	3,1	12,2	EB	
1296	8,0	2,6	3,2	1,5	2,1	12,9	EB	

Information:

EB = EPDM, schwarz

Toleranzen nach (DIN ISO 3302, Teil 2 M2F)
Irrtum vorbehalten

Information:

EB = EPDM, black

General measuring tolerances (DIN ISO 3302, section 2 M2F)
Errors excepted



PUFFER MIT ZAPFEN
BUFFER WITH PIN

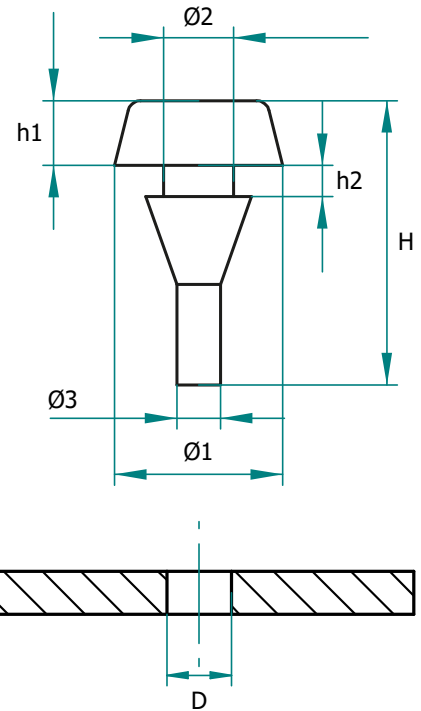

Artikel Nr. <i>Part no.</i>	Kopf Ø <i>Head Ø</i>	Kopfhöhe <i>Head height</i>	Hals Ø <i>Neck Ø</i>	Spalt <i>Gap</i>	Zapfen Ø <i>Tap Ø</i>	Gesamthöhe <i>Total height</i>	Material <i>Material</i>	
	Ø1	h1	Ø2	h2	Ø3	H		
1300	10,0	4,0	5,5	1,0	3,1	14,5	EB	
1301	10,0	4,0	5,5	2,0	3,1	15,4	EB	
1304	8,5	2,0	5,0	3,0	3,0	10,9	EB	
1317	14,0	5,0	7,5	1,3	5,0	16,5	EB	
1320	12,0	4,5	4,0	2,5	3,0	18,4	EB	
1321	7,8	6,5	4,1	2,5	3,1	19,5	EB	
1326	6,0	3,0	2,5	2,5	1,7	10,5	EB	

Information:
EB = EPDM, schwarz

Toleranzen nach (DIN ISO 3302, Teil 2 M2F)
Irrtum vorbehalten

Information:
EB = EPDM, black

General measuring tolerances (DIN ISO 3302, section 2 M2F)
Errors excepted



PUFFER MIT ZAPFEN
BUFFER WITH PIN

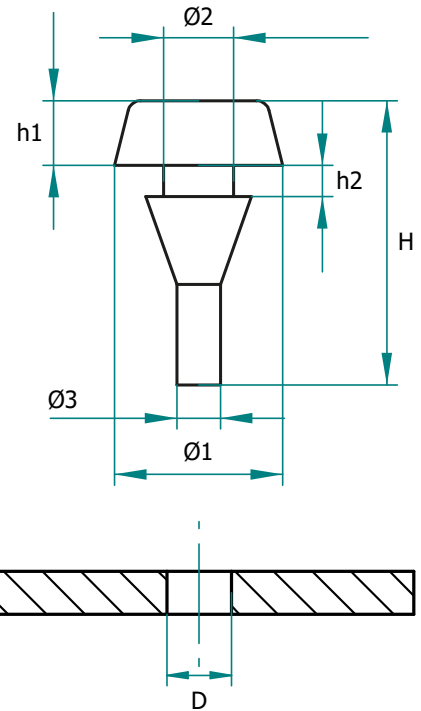

Artikel Nr. <i>Part no.</i>	Kopf Ø <i>Head Ø</i>	Kopfhöhe <i>Head height</i>	Hals Ø <i>Neck Ø</i>	Spalt <i>Gap</i>	Zapfen Ø <i>Tap Ø</i>	Gesamthöhe <i>Total height</i>	Material <i>Material</i>	
	Ø1	h1	Ø2	h2	Ø3	H		
1329	8,0	2,5	3,5	1,2	2,2	9,4	EB	
1336	13,0	4,7	6,0	1,5	4,8	13,8	EB	
1337	13,0	7,5	4,6	1,2	4,5	20,0	EB	
1338	14,2	8,7	6,0	1,5	4,0	25,6	EB	
1339	13,0	6,5	6,0	1,5	4,8	15,8	EB	
1340	13,0	7,0	6,0	2,5	4,8	19,0	EB	
1341	17,5	13,3	8,0	0,8	3,9	25,2	EB	

Information:

EB = EPDM, schwarz

Toleranzen nach (DIN ISO 3302, Teil 2 M2F)
Irrtum vorbehalten

Information:

EB = EPDM, black

General measuring tolerances (DIN ISO 3302, section 2 M2F)
Errors excepted



PUFFER MIT ZAPFEN
BUFFER WITH PIN

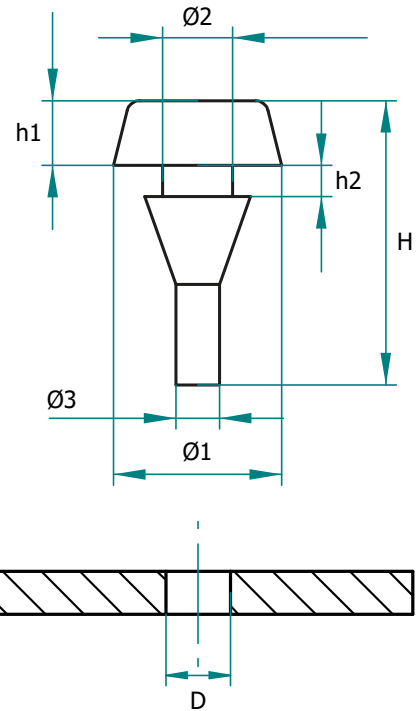

Artikel Nr. <i>Part no.</i>	Kopf Ø <i>Head Ø</i>	Kopfhöhe <i>Head height</i>	Hals Ø <i>Neck Ø</i>	Spalt <i>Gap</i>	Zapfen Ø <i>Tap Ø</i>	Gesamthöhe <i>Total height</i>	Material <i>Material</i>	
	Ø1	h1	Ø2	h2	Ø3	H		
1343	13,0	12,0	5,5	3,0	4,4	26,2	EB	
1344	14,2	6,5	6,0	1,9	4,0	23,4	EB	

Information:

EB = EPDM, schwarz

Toleranzen nach (DIN ISO 3302, Teil 2 M2F)
Irrtum vorbehalten

Information:

EB = EPDM, black

General measuring tolerances (DIN ISO 3302, section 2 M2F)
Errors excepted



PUFFER OHNE ZAPFEN
BUFFER WITHOUT PIN

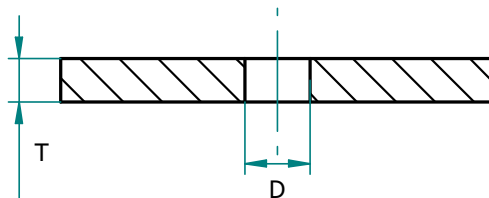
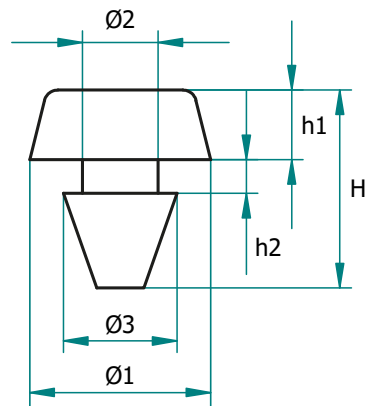

Artikel Nr. <i>Part no.</i>	Kopf Ø <i>Head Ø</i>	Kopfhöhe <i>Head height</i>	Hals Ø <i>Neck Ø</i>	Spalt <i>Gap</i>	Konus Ø <i>Cone Ø</i>	Gesamthöhe <i>Total height</i>	Material <i>Material</i>	
	Ø1	h1	Ø2	h2	Ø3	H		
1244	6,0	1,8	3,0	1,7	5,0	5,4	EB	
1246	6,0	2,1	3,0	2,2	5,0	7,6	EB	
1298	13,0	3,5	5,0	1,5	7,0	12,0	EB	
1299	9,0	5,0	5,0	1,5	7,0	13,6	EB	
1303	9,8	2,0	5,6	2,5	7,5	9,5	EB	
1306	9,0	1,0	4,5	2,2	5,5	7,5	EB	
1308	9,0	2,1	4,5	2,2	5,5	8,6	EB	

Information:

EB = EPDM, schwarz

Toleranzen nach (DIN ISO 3302, Teil 2 M2F)
Irrtum vorbehalten

Information:

EB = EPDM, black

General measuring tolerances (DIN ISO 3302, section 2 M2F)
Errors excepted



PUFFER OHNE ZAPFEN
BUFFER WITHOUT PIN

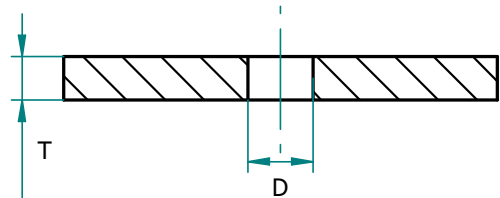
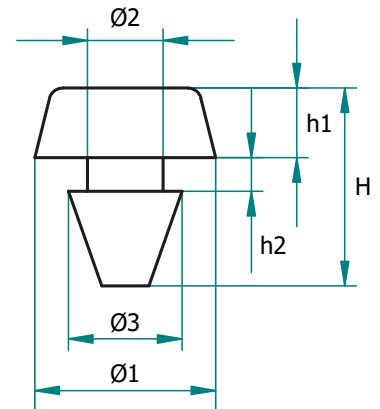

Artikel Nr. <i>Part no.</i>	Kopf Ø <i>Head Ø</i>	Kopfhöhe <i>Head height</i>	Hals Ø <i>Neck Ø</i>	Spalt <i>Gap</i>	Konus Ø <i>Cone Ø</i>	Gesamthöhe <i>Total height</i>	Material <i>Material</i>	
	Ø1	h1	Ø2	h2	Ø3	H		
1309	10,0	3,2	6,4	1,1	7,8	6,5	EB	
1310	9,5	2,5	4,5	1,2	7,5	7,7	EB	
1311	9,8	3,0	5,6	2,5	7,5	10,5	EB	
1312	12,0	2,0	5,0	2,0	6,5	6,0	EB	
1313	11,8	5,5	5,5	2,9	7,4	11,0	EB	
1314	12,0	4,2	6,0	3,0	10,0	9,3	EB	
1315	14,0	5,0	7,5	2,0	10,0	12,1	EB	

Information:

EB = EPDM, schwarz

Toleranzen nach (DIN ISO 3302, Teil 2 M2F)
Irrtum vorbehalten

Information:

EB = EPDM, black

General measuring tolerances (DIN ISO 3302, section 2 M2F)
Errors excepted



PUFFER OHNE ZAPFEN
BUFFER WITHOUT PIN

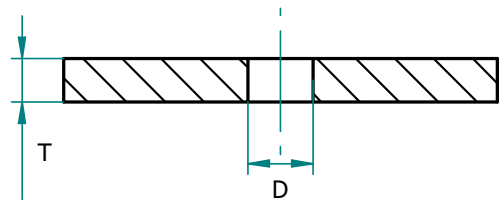
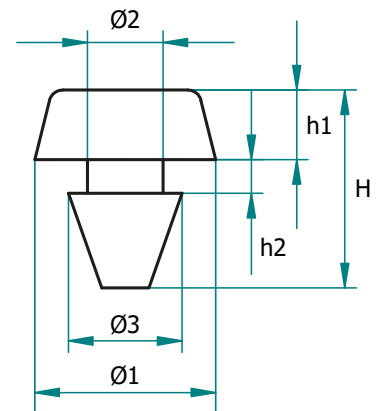

Artikel Nr. <i>Part no.</i>	Kopf Ø <i>Head Ø</i>	Kopfhöhe <i>Head height</i>	Hals Ø <i>Neck Ø</i>	Spalt <i>Gap</i>	Konus Ø <i>Cone Ø</i>	Gesamthöhe <i>Total height</i>	Material <i>Material</i>	
	Ø1	h1	Ø2	h2	Ø3	H		
1316	14,0	5,0	7,5	1,5	10,0	11,1	EB	
1318	13,0	3,0	7,0	1,5	9,0	9,7	EB	
1319	12,5	3,0	6,0	2,0	8,3	12,0	EB	
1322	9,5	2,5	5,5	1,2	7,5	7,7	EB	
1323	12,0	5,5	5,5	5,0	7,3	13,1	EB	
1325	7,0	3,5	5,2	1,4	7,8	6,9	EB	
1330	5,5	7,0	3,5	2,5	5,5	12,5	EB	

Information:

EB = EPDM, schwarz

Toleranzen nach (DIN ISO 3302, Teil 2 M2F)
Irrtum vorbehalten

Information:

EB = EPDM, black

General measuring tolerances (DIN ISO 3302, section 2 M2F)
Errors excepted



PUFFER OHNE ZAPFEN
BUFFER WITHOUT PIN

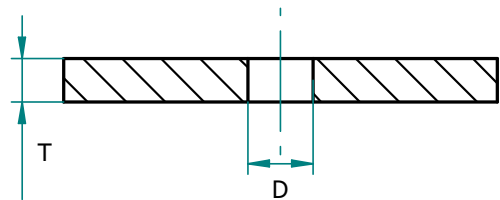
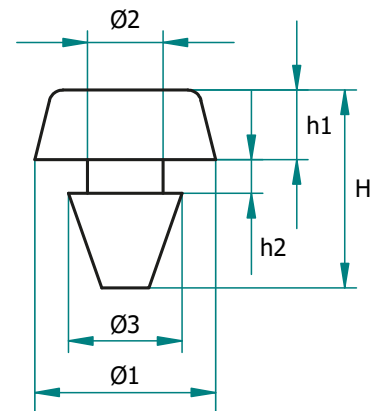

Artikel Nr. <i>Part no.</i>	Kopf Ø <i>Head Ø</i>	Kopfhöhe <i>Head height</i>	Hals Ø <i>Neck Ø</i>	Spalt <i>Gap</i>	Konus Ø <i>Cone Ø</i>	Gesamthöhe <i>Total height</i>	Material <i>Material</i>	
	Ø1	h1	Ø2	h2	Ø3	H		
1332	9,5	2,7	5,8	2,0	8,0	7,0	EB	
1334	11,7	4,5	7,8	2,0	10,0	9,4	EB	
1345	15,0	5,0	10,2	1,5	13,0	9,6	EB	
1346	7,8	7,0	4,0	5,0	4,8	14,2	EB	
1347	7,5	4,1	4,0	6,3	5,0	12,6	EB	
1350	7,4	2,5	3,5	2,5	5,7	7,0	EB	

Information:

EB = EPDM, schwarz

Toleranzen nach (DIN ISO 3302, Teil 2 M2F)
Irrtum vorbehalten

Information:

EB = EPDM, black

General measuring tolerances (DIN ISO 3302, section 2 M2F)
Errors excepted



PUFFER SONDERFORM
BUFFER SPECIAL FORM

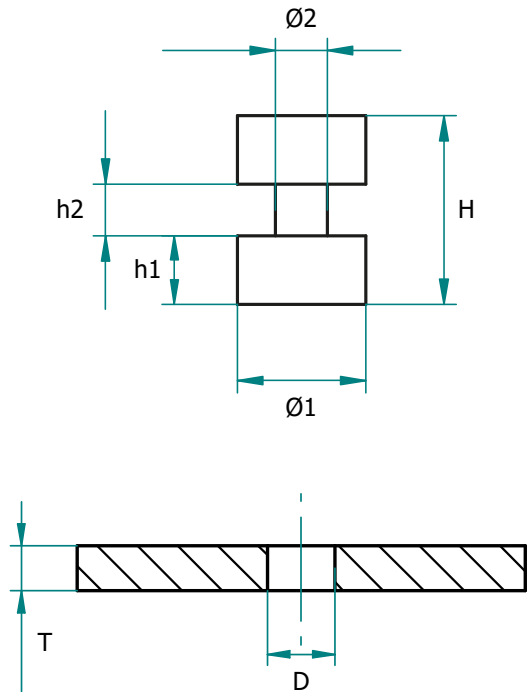

Artikel Nr. <i>Part no.</i>	Kopf Ø <i>Head Ø</i>	Kopfhöhe <i>Head height</i>	Hals Ø <i>Neck Ø</i>	Spalt <i>Gap</i>	Gesamthöhe <i>Total height</i>	Material <i>Material</i>	
	Ø1	h1	Ø2	h2	H		
1294	3,7	2,0	2,5	1,5	5,5	EB	
1328	5,2	1,5	3,0	2,4	5,4	EB	

Information:

EB = EPDM, schwarz

Toleranzen nach (DIN ISO 3302, Teil 2 M2F)
Irrtum vorbehalten

Information:

EB = EPDM, black

General measuring tolerances (DIN ISO 3302, section 2 M2F)
Errors excepted



SOFTPUFFER - FORM 1
SOFTBUFFER - SHAPE 1

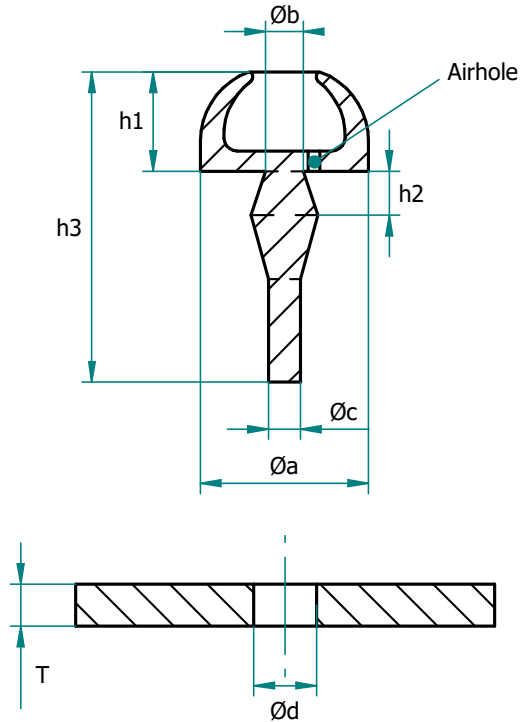

Artikel Nr. <i>Part no.</i>	Kopf \varnothing <i>Head \varnothing</i>	Kopfhöhe <i>Head height</i>	Hals \varnothing <i>Neck \varnothing</i>	Spalt <i>Gap</i>	Zapfen \varnothing <i>Tap \varnothing</i>	Gesamthöhe <i>Total height</i>		Federweg <i>pitch of spring</i>	T/D <i>T/D</i>	T/D <i>T/D</i>	Material <i>Material</i>	
	a	h1	b	h2	$\varnothing c$	h3	$\varnothing d$					
1279	10,0	6,0	2,5	1 - 2,5	2,0	18,5	-	$\approx 4,0$	1 / 2,2	2,5 / 2,5	EB	
1280	14,5	10,0	3,8	1 - 2,5	3,0	23,5	-	$\approx 7,5$	1 / 3,3	2,5 / 3,5	EB	

Information:

EB = EPDM, schwarz

Toleranzen nach (DIN ISO 3302, Teil 2 M2F)
Irrtum vorbehalten

Information:

EB = EPDM, black

General measuring tolerances (DIN ISO 3302, section 2 M2F)
Errors excepted



SOFTPUFFER - FORM 2
SOFTBUFFER - SHAPE 2

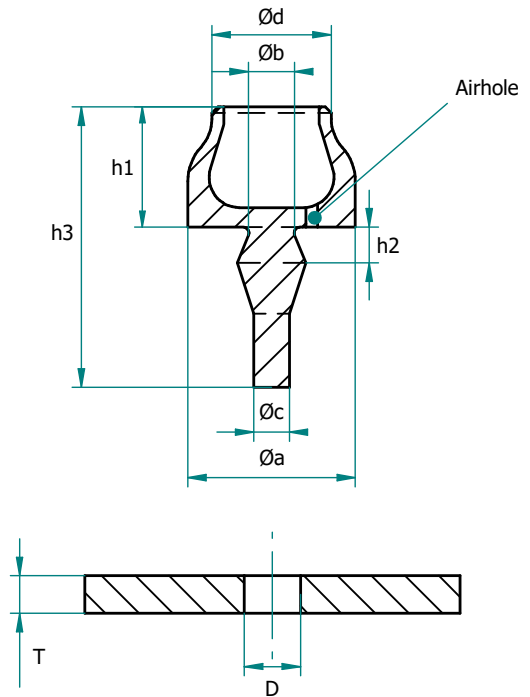

Artikel Nr. Part no.	Kopf \varnothing Head \varnothing	Kopfhöhe Head height	Hals \varnothing Neck \varnothing	Spalt Gap	Zapfen \varnothing Tap \varnothing	Gesamthöhe Total height		Federweg pitch of spring	T/D T/D	T/D T/D	Material Material	
	a	h1	b	h2	$\varnothing c$	h3	$\varnothing d$					
1351	8,0	5,0	2,5	1 - 3,0	2,0	19,0	6,5	$\approx 2,7$	1 / 2,5	3 / 3,0	EB	
1352	11,0	7,0	3,2	1 - 3,0	2,8	21,0	9,0	$\approx 3,8$	1 / 2,8	3 / 3,0	EB	
1353	14,0	10,0	3,8	1 - 3,0	3,0	23,3	10,0	$\approx 5,5$	1 / 3,8	3 / 4,0	EB	
1354	17,0	11,8	4,2	1 - 3,0	3,0	25,0	12,5	$\approx 6,5$	1 / 4,8	3 / 5,0	EB	
1355	20,5	14,0	5,1	2 - 4,0	3,7	29,6	15,3	$\approx 7,5$	2 / 5,5	4 / 6,5	EB	

Information:

EB = EPDM, schwarz

Toleranzen nach (DIN ISO 3302, Teil 2 M2F)
Irrtum vorbehalten

Information:

EB = EPDM, black

General measuring tolerances (DIN ISO 3302, section 2 M2F)
Errors excepted



SOFTPUFFER - FORM 3
SOFTBUFFER - SHAPE 3

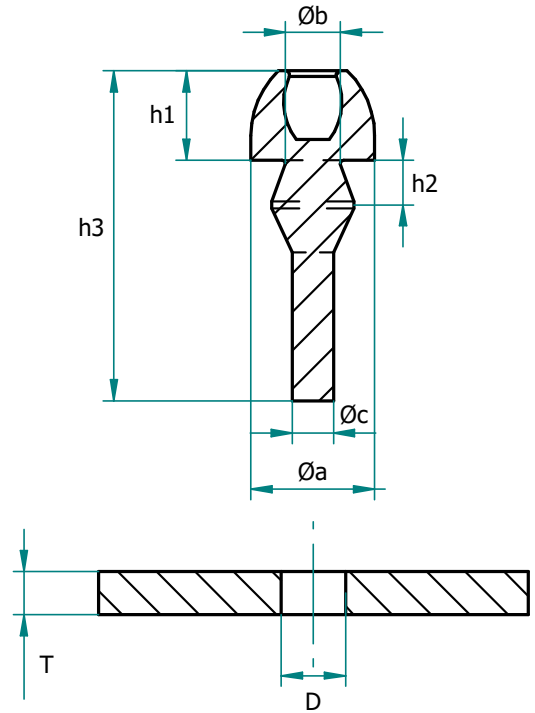

Artikel Nr. <i>Part no.</i>	Kopf \varnothing <i>Head \varnothing</i>	Kopfhöhe <i>Head height</i>	Hals \varnothing <i>Neck \varnothing</i>	Spalt <i>Gap</i>	Zapfen \varnothing <i>Tap \varnothing</i>	Gesamthöhe <i>Total height</i>		Federweg <i>pitch of spring</i>	T/D <i>T/D</i>	T/D <i>T/D</i>	Material <i>Material</i>
	a	h1	b	h2	$\varnothing c$	h3	$\varnothing d$				
3501	9,2	6,5	4,0	1 - 3,0	3,2	24,0	-	$\approx 3,0$	1 / 4,0	3 / 4,5	EB



Information:

EB = EPDM, schwarz
ohne Lüftungsbohrung
Toleranzen nach (DIN ISO 3302, Teil 2 M2F)
Irrtum vorbehalten

Information:

EB = EPDM, black
without airhole
General measuring tolerances (DIN ISO 3302, section 2 M2F)
Errors excepted



SOFTPUFFER - FORM 4
SOFTBUFFER - SHAPE 4

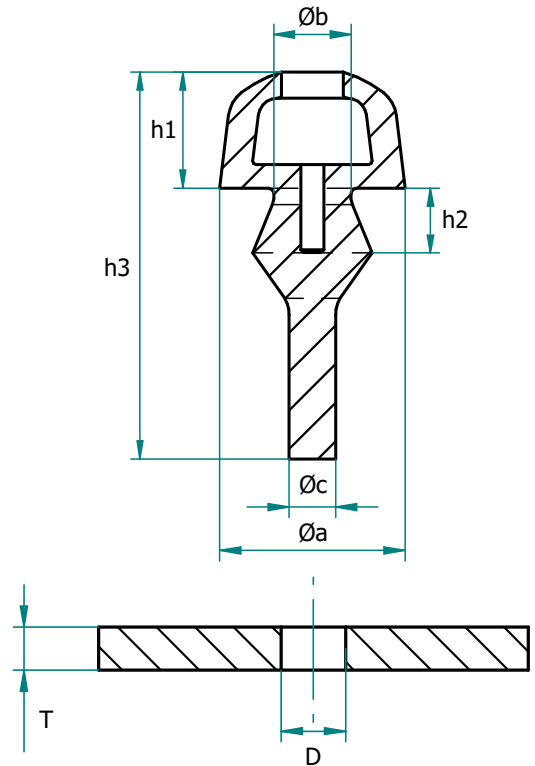



Artikel Nr. <i>Part no.</i>	Kopf \varnothing <i>Head \varnothing</i>	Kopfhöhe <i>Head height</i>	Hals \varnothing <i>Neck \varnothing</i>	Spalt <i>Gap</i>	Zapfen \varnothing <i>Tap \varnothing</i>	Gesamthöhe <i>Total height</i>		Federweg <i>pitch of spring</i>	T/D <i>T/D</i>	T/D <i>T/D</i>	Material <i>Material</i>
	a	h1	b	h2	$\varnothing c$	h3	$\varnothing d$				
3502	12,0	7,5	5,0	1 - 3,0	3,0	25,0	-	$\approx 3,0$	1 / 5	3 / 5,5	EB

<p>Information: EB = EPDM, schwarz ohne Lüftungsbohrung Toleranzen nach (DIN ISO 3302, Teil 2 M2F) Irrtum vorbehalten</p>	<p>Information: EB = EPDM, black without airhole General measuring tolerances (DIN ISO 3302, section 2 M2F) Errors excepted</p>
--	--

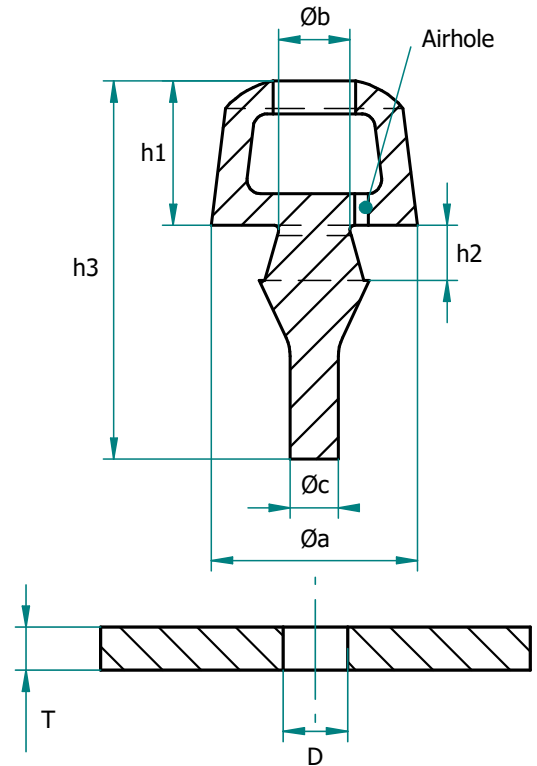

SOFTPUFFER - FORM 5
SOFTBUFFER - SHAPE 5



Artikel Nr. <i>Part no.</i>	Kopf \varnothing <i>Head \varnothing</i>	Kopfhöhe <i>Head height</i>	Hals \varnothing <i>Neck \varnothing</i>	Spalt <i>Gap</i>	Zapfen \varnothing <i>Tap \varnothing</i>	Gesamthöhe <i>Total height</i>		Federweg <i>pitch of spring</i>	T/D <i>T/D</i>	T/D <i>T/D</i>	Material <i>Material</i>	
	a	h1	b	h2	$\varnothing c$	h3	$\varnothing d$					
3503	15,0	10,5	5,2	1 - 3,0	3,5	27,5	-	$\approx 5,0$	1 / 5	3 / 5,5	EB	
3504	18,5	13,5	5,5	1 - 3,0	3,5	36,0	-	$\approx 8,0$	1 / 5,5	3 / 6	EB	

Information:

EB = EPDM, schwarz

Toleranzen nach (DIN ISO 3302, Teil 2 M2F)
Irrtum vorbehalten

Information:

EB = EPDM, black

General measuring tolerances (DIN ISO 3302, section 2 M2F)
Errors excepted



GUMMISTOPFEN
RUBBER STOPS

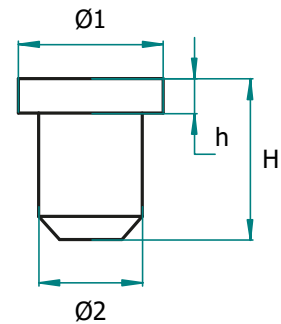
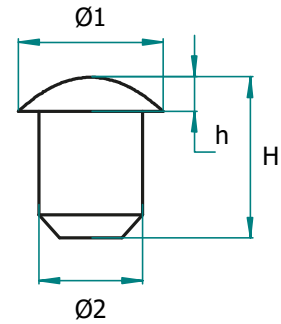

Artikel Nr. <i>Part no.</i>	Kopf Ø <i>Head Ø</i>	Kopfhöhe <i>Head height</i>	Schaft Ø <i>Shaft Ø</i>	Gesamthöhe <i>Total height</i>	Material <i>Material</i>	
	Ø1	h	Ø2	H		
1659	5,3	2,0	3,0	5,0	EB	
1663	12,0	4,2	9,0	13,0	EB	
1664	7,4	2,4	4,5	7,0	EB	
1666	6,0	2,0	4,0	4,7	EB	
1668	12,0	1,5	8,0	10,3	EB	
1669	7,0	1,1	4,0	7,1	EB	
1671	6,0	2,0	4,0	6,0	EB	

Information:

EB = EPDM, schwarz
1) = mit Durchgangsloch
Toleranzen nach (DIN ISO 3302, Teil 2 M2F)
Irrtum vorbehalten

Information:

EB = EPDM, black
1) = with hole
General measuring tolerances (DIN ISO 3302, section 2 M2F)
Errors excepted



GUMMISTOPFEN
RUBBER STOPS

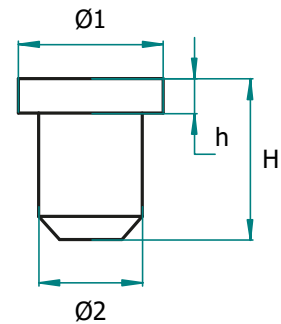
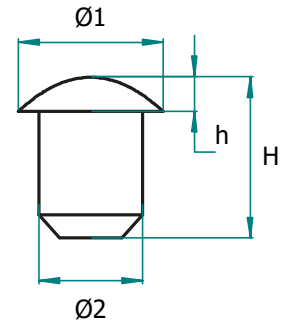

Artikel Nr. <i>Part no.</i>	Kopf Ø <i>Head Ø</i>	Kopfhöhe <i>Head height</i>	Schaft Ø <i>Shaft Ø</i>	Gesamthöhe <i>Total height</i>	Material <i>Material</i>	
	Ø1	h	Ø2	H		
1676	6,0	1,5	4,0	7,7	EB	
1677	9,5	2,0	7,2	8,0	EB	
1684	9,7	2,1	6,0	8,0	EB	
1690	9,8	3,1	7,5	8,0	EB	
1691 ¹⁾	10,0	2,6	6,2	10,5	EB	
1692	9,5	2,0	6,0	7,0	EB	
1695	11,8	1,5	8,1	7,8	EB	

Information:

EB = EPDM, schwarz
1) = mit Durchgangsloch
Toleranzen nach (DIN ISO 3302, Teil 2 M2F)
Irrtum vorbehalten

Information:

EB = EPDM, black
1) = with hole
General measuring tolerances (DIN ISO 3302, section 2 M2F)
Errors excepted



GUMMISTOPFEN
RUBBER STOPS

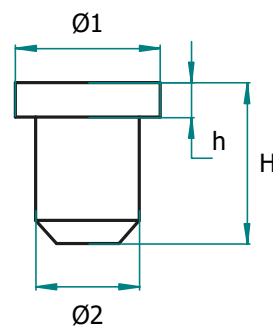
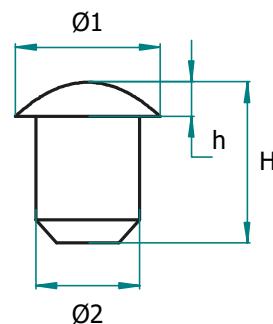

Artikel Nr. <i>Part no.</i>	Kopf Ø <i>Head Ø</i>	Kopfhöhe <i>Head height</i>	Schaft Ø <i>Shaft Ø</i>	Gesamthöhe <i>Total height</i>	Material <i>Material</i>	
	Ø1	h	Ø2	H		
1702	7,5	1,7	5,0	6,3	EB	
1703	12,0	1,5	8,1	6,2	EB	
1707	6,0	2,7	3,3	10,6	EB	
1709	12,8	3,1	7,1	8,5	EB	
1716 ¹⁾	9,5	2,0	6,0	7,0	EB	
1722	8,5	4,6	7,2	9,0	EB	
1723	8,5	3,0	7,1	7,5	EB	

Information:

EB = EPDM, schwarz

1) = mit Durchgangsloch

Toleranzen nach (DIN ISO 3302, Teil 2 M2F)

Irrtum vorbehalten

Information:

EB = EPDM, black

1) = with hole

General measuring tolerances (DIN ISO 3302, section 2 M2F)

Errors excepted



GUMMISTOPFEN
RUBBER STOPS

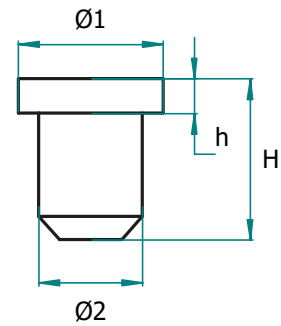
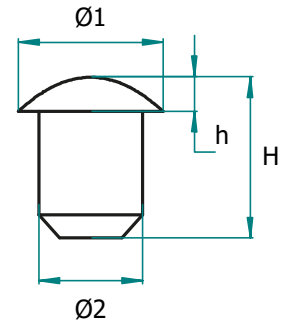

Artikel Nr. <i>Part no.</i>	Kopf Ø <i>Head Ø</i>	Kopfhöhe <i>Head height</i>	Schaft Ø <i>Shaft Ø</i>	Gesamthöhe <i>Total height</i>	Material <i>Material</i>	
	Ø1	h	Ø2	H		
1726	8,5	3,7	7,1	8,2	EB	

Information:

EB = EPDM, schwarz
1) = mit Durchgangsloch
Toleranzen nach (DIN ISO 3302, Teil 2 M2F)
Irrtum vorbehalten

Information:

EB = EPDM, black
1) = with hole
General measuring tolerances (DIN ISO 3302, section 2 M2F)
Errors excepted



STOPFEN
PLUGS



KAROSSERIESTOPFEN
BLANKING PLUG

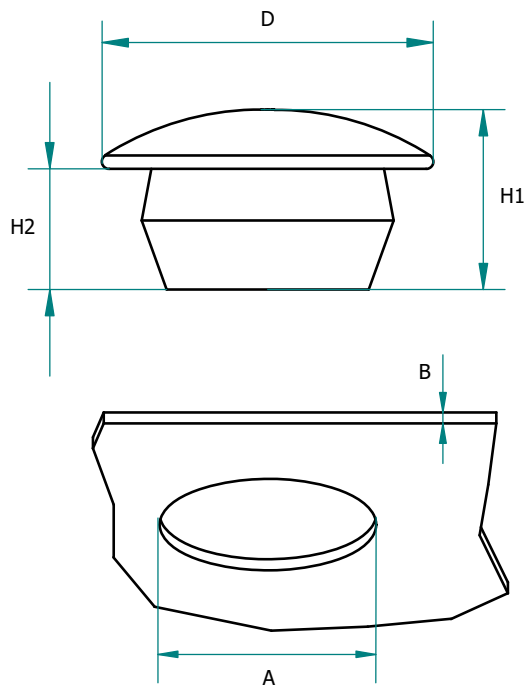

Artikel Nr. <i>Part no.</i>	Nennmaß <i>Nominal size</i>	Loch Ø <i>Panel hole size</i>	Wandstärke <i>Panel thickness</i>	Gesamt Ø <i>Total Ø</i>	Gesamthöhe <i>Total height</i>	Einbaumaß <i>Installation dimension</i>	Material <i>Material</i>	
		A	B	D	H1	H2		
1500	M 6	6	1 - 3,0	12,0	11,5	8,5	EB	
1501	M 8	8	1 - 3,0	14,0	11,5	8,5	EB	
1502	M 10	10	1 - 3,0	16,0	12,0	8,5	EB	
1503	M 12	12	1 - 3,0	18,5	12,0	8,5	EB	
1504	M 16	16	1 - 3,0	23,0	12,5	8,5	EB	
1505	M 20	20	1 - 3,0	27,0	13,0	8,5	EB	
1506	M 25	25	1 - 3,0	32,5	13,0	8,5	EB	

Information:

EB = EPDM, schwarz

Toleranzen nach (DIN ISO 3302, Teil 2 M2F)
Irrtum vorbehalten

Information:

EB = EPDM, black

General measuring tolerances (DIN ISO 3302, section 2 M2F)
Errors excepted



KAROSSERIESTOPFEN
BLANKING PLUG

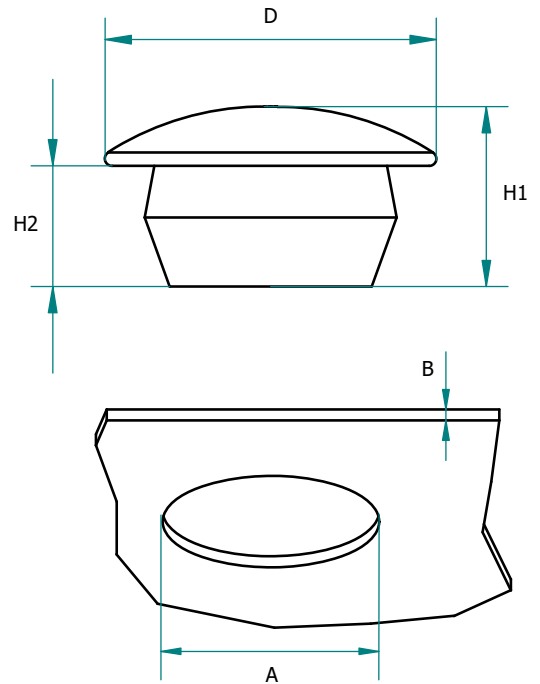

Artikel Nr. <i>Part no.</i>	Nennmaß <i>Nominal size</i>	Loch Ø <i>Panel hole size</i>	Wandstärke <i>Panel thickness</i>	Gesamt Ø <i>Total Ø</i>	Gesamthöhe <i>Total height</i>	Einbaumaß <i>Installation dimension</i>	Material <i>Material</i>	
		A	B	D	H1	H2		
1507	M 32	32	1 - 3,0	39,5	13,0	8,5	EB	

Information:

EB = EPDM, schwarz

Toleranzen nach (DIN ISO 3302, Teil 2 M2F)
Irrtum vorbehalten

Information:

EB = EPDM, black

General measuring tolerances (DIN ISO 3302, section 2 M2F)
Errors excepted



LAMELLENSTOPFEN LAMELLAR PLUGS

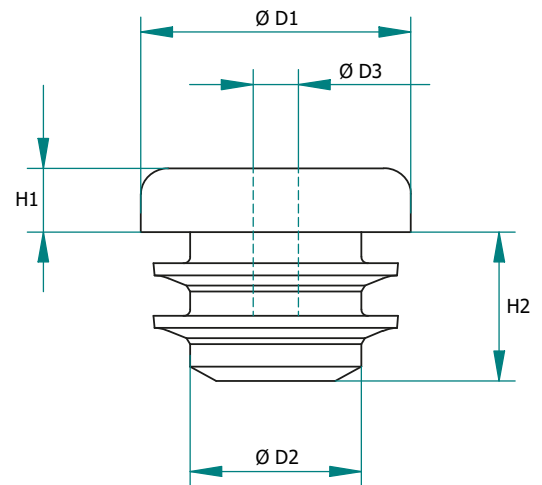

Artikel Nr. Part no.	Nennmaß Nominal size	Durchmesserbereich Diameter range	Kopf Ø Head Ø	Kopfhöhe Head height	Schaftlänge Shaft length	Schaft Ø Shaft Ø	Sackloch Ø Blind hole Ø	Material Material	
			ØD1	H1	H2	Ø D2	Ø D3		
1611	M 5	4,0 - 5,5	8,0	2,5	7,00	3,50	1,50	EB, NB, SR	
1612	M 6	5,5 - 7,0	9,0	2,8	7,00	4,50	1,50	EB, NB, SR	
1613	M 8	7,0 - 8,5	10,5	3,0	7,00	6,50	1,70	EB, NB, SR	
1614	M 10	8,5 - 10,0	12,0	3,0	7,00	7,50	2,00	EB, NB, SR	
1615	M 12	10,0 - 12,0	14,0	3,0	7,00	8,80	3,00	EB, NB, SR	
1616	M 16	12,0 - 16,0	18,0	4,0	9,80	10,60	4,00	EB, NB, SR	
1617	M 20	16,0 - 20,0	25,0	5,5	13,70	12,90	6,30	EB, NB, SR	

Information:

EB = EPDM, schwarz ; NB = NBR, schwarz ; SR = Silikon, rot

Toleranzen nach (DIN ISO 3302, Teil 2 M2F)
Irrtum vorbehalten

Information:

EB = EPDM, black ; NB = NBR, black ; SR = Silicon, red

General measuring tolerances (DIN ISO 3302, section 2 M2F)
Errors excepted



LAMELLENSTOPFEN
LAMELLAR PLUGS

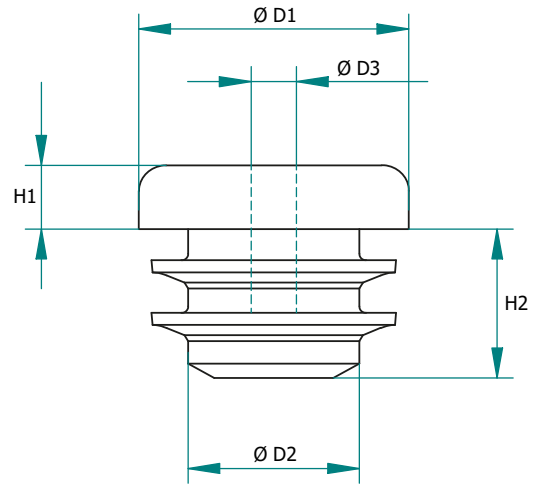

Artikel Nr. <i>Part no.</i>	Nennmaß <i>Nominal size</i>	Durchmesserbereich <i>Diameter range</i>	Kopf Ø <i>Head Ø</i>	Kopfhöhe <i>Head height</i>	Schaftlänge <i>Shaft length</i>	Schaft Ø <i>Shaft Ø</i>	Sackloch Ø <i>Blind hole Ø</i>	Material <i>Material</i>	
			ØD1	H1	H2	Ø D2	Ø D3		
1618	M 24	20,0 - 24,0	30,0	6,0	17,00	16,70	9,30	EB, NB, SR	

Information:

EB = EPDM, schwarz ; NB = NBR, schwarz ; SR = Silikon, rot

Toleranzen nach (DIN ISO 3302, Teil 2 M2F)
Irrtum vorbehalten

Information:

EB = EPDM, black ; NB = NBR, black ; SR = Silicon, red

General measuring tolerances (DIN ISO 3302, section 2 M2F)
Errors excepted



STECKFUSS
RUBBER STOPPER

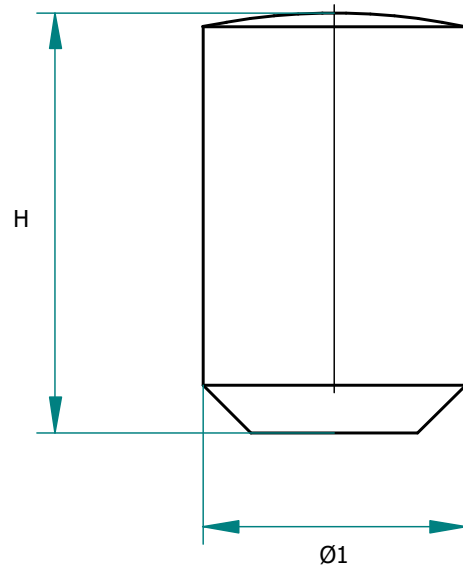

Artikel Nr. <i>Part no.</i>	Gesamt Ø <i>Total Ø</i>	Gesamthöhe <i>Total height</i>	Material <i>Material</i>	
	Ø1	H		
1649 ¹⁾	4,5	7,7	EB	
1683	6,0	9,5	EB	
1699	5,0	6,3	EB	
1700	5,0	6,0	EB	

Information:

EB = EPDM, schwarz
1) = Durchgangsbohrung von Ø 1,2mm
Toleranzen nach (DIN ISO 3302, Teil 2 M2F)
Irrtum vorbehalten

Information:

EB = EPDM, black
1) = drill-hole Ø 1,2mm
General measuring tolerances (DIN ISO 3302, section 2 M2F)
Errors excepted



TÜLLENPUFFER
RUBBER BUMPER

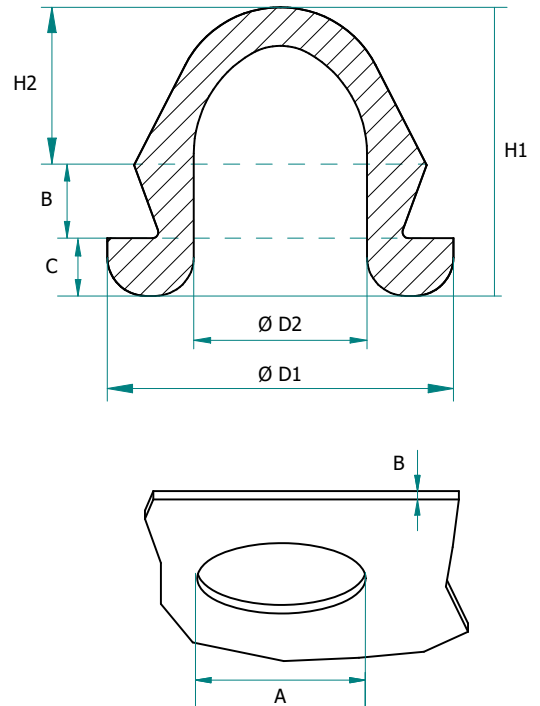

Artikel Nr. <i>Part no.</i>	Nennmaß <i>Nominal size</i>	Loch Ø <i>Panel hole size</i>	Wandstärke <i>Panel thickness</i>	Bundhöhe <i>Collar height</i>	Gesamt Ø <i>Total Ø</i>	Loch Ø <i>Hole Ø</i>	Gesamthöhe <i>Total height</i>	Material <i>Material</i>	
		A	B		Ø D1		H1		
3550	M10	10,5	1 - 3,0	3,0	15,0	7,0	13,0	EB	
3551	M12	12,5	1 - 3,0	3,0	18,0	9,0	15,0	EB	
3552	M16	16,5	1 - 3,0	3,0	22,0	12,2	17,0	EB	
3553	M20	20,5	1 - 3,0	3,0	26,0	15,2	19,0	EB	

Information:

EB = EPDM, schwarz

Toleranzen nach (DIN ISO 3302, Teil 2 M2F)
Irrtum vorbehalten

Information:

EB = EPDM, black

General measuring tolerances (DIN ISO 3302, section 2 M2F)
Errors excepted



ABDECKKAPPEN
MASKING CAPS

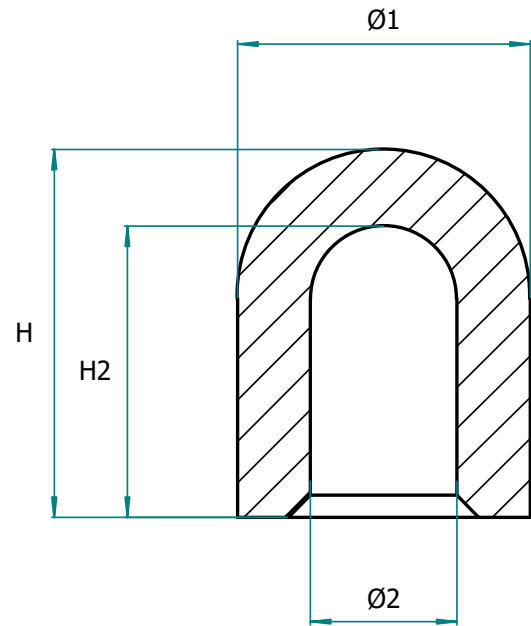

Artikel Nr. <i>Part no.</i>	Gesamt Ø <i>Total Ø</i>	Loch Ø <i>Hole Ø</i>	Gesamthöhe <i>Total height</i>	Höhe innen <i>Height inner</i>	Material <i>Material</i>	
	Ø1	Ø2	H	H2		
1712	13,0	8,2	11,0	9,0	EB	
1732	12,3	10,6	25,0	24,1	EB	
1913	5,5	2,7	5,0	3,8	EB	
1918	7,0	2,4	9,0	6,4	EB	

Information:

EB = EPDM, schwarz

Toleranzen nach (DIN ISO 3302, Teil 2 M2F)
Irrtum vorbehalten

Information:

EB = EPDM, black

General measuring tolerances (DIN ISO 3302, section 2 M2F)
Errors excepted





TÜLLEN
GROMMETS

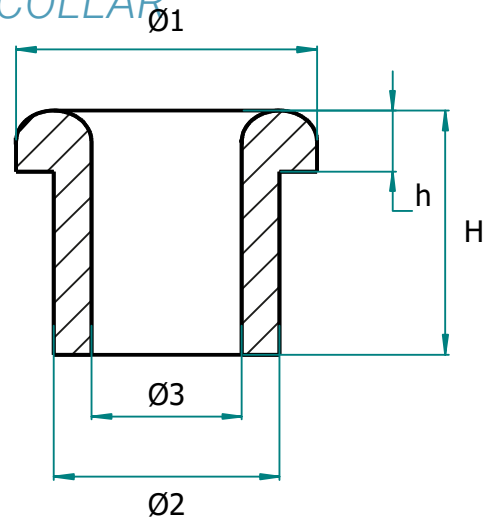

KABELDURCHFÜHRUNG MIT EINSEITIGEM BUND CABLE GROMMETS WITH ONE-SIDED COLLAR



Artikel Nr. <i>Part no.</i>	Gesamt Ø <i>Total Ø</i>	Loch Ø <i>Hole Ø</i>	Kabel Ø <i>Cable Ø</i>	Bundhöhe <i>Collar height</i>	Gesamthöhe <i>Total height</i>	Material <i>Material</i>	
	Ø1	Ø2	Ø3	h	H		
1041	13,7	10,0	5,8	4,0	12,0	EB	
1087	14,0	10,0	6,0	4,0	10,0	EB	

Information:

EB = EPDM, schwarz

Toleranzen nach (DIN ISO 3302, Teil 2 M2F)
Irrtum vorbehalten

Information:

EB = EPDM, black

General measuring tolerances (DIN ISO 3302, section 2 M2F)
Errors excepted



KABELDURCHFÜHRUNG MIT INNENLIEGENDER DICHTLIPPE CABLE GROMMET WITH INSIDE SEALING LIP

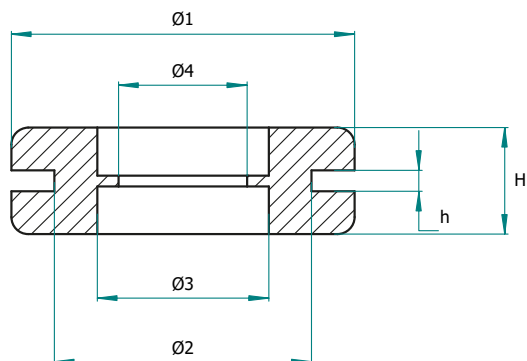

Artikel Nr. <i>Part no.</i>	Gesamt Ø <i>Total Ø</i>	Loch Ø <i>Hole Ø</i>	Ø3 <i>Ø3</i>	Ø4 <i>Ø4</i>	Spalt <i>Gap</i>	Gesamthöhe <i>Total height</i>	Material <i>Material</i>	
	Ø1	Ø2	Ø3	Ø4	h	H		
1047	8,0	6,0	3,8	2,5	2,0	4,2	EB	
1065	19,0	15,0	10,7	7,7	1,7	8,1	EB	
1088	12,0	9,8	6,8	6,0	1,0	8,1	EB	
1093	16,0	11,0	8,8	6,3	2,0	10,2	EB	
1094	30,0	20,0	18,0	14,0	2,3	10,3	EB	
1095	35,0	28,0	24,0	20,0	2,0	10,0	EB	
1096	20,0	16,5	13,2	10,4	2,0	10,0	EB	

Information:

EB = EPDM, schwarz

Toleranzen nach (DIN ISO 3302, Teil 2 M2F)
Irrtum vorbehalten

Information:

EB = EPDM, black

General measuring tolerances (DIN ISO 3302, section 2 M2F)
Errors excepted



KABELDURCHFÜHRUNGEN MIT ASYMMETRISCHEM BUND CABLE GROMMETS WITH ASYMMETRIC COLLAR

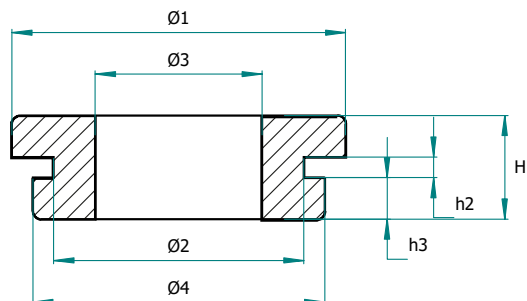

Artikel Nr. Part no.	Gesamt Ø Total Ø	Loch Ø Hole Ø	Kabel Ø Cable Ø	Ø4 Ø4	Gesamthöhe Total height	Spalt Gap		Material Material	
	Ø1	Ø2	Ø3	Ø4	H	h2	h3		
0990	7,0	4,0	2,0	6,2	4,0	1,0	1,2	EB	
1000	6,0	4,0	1,6	-	5,0	1,5	1,8	EB	
1019	12,0	6,0	4,0	9,0	6,0	1,5	2,0	EB	
1036	17,0	11,8	10,0	-	7,0	2,0	2,0	EB	
1058	16,7	10,0	6,0	13,7	10,0	1,6	4,2	EB	

Information:

EB = EPDM, schwarz

Toleranzen nach (DIN ISO 3302, Teil 2 M2F)
Irrtum vorbehalten

Information:

EB = EPDM, black

General measuring tolerances (DIN ISO 3302, section 2 M2F)
Errors excepted



KABELDURCHFÜHRUNGEN MIT RADIUS CABLE GROMMETS WITH RADIUS

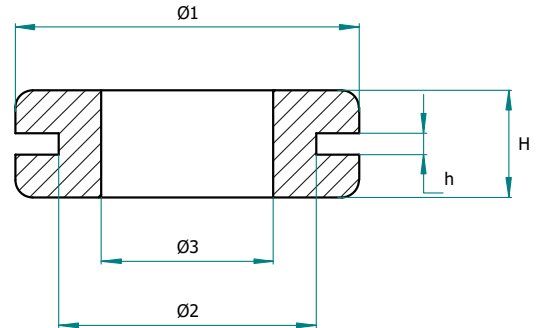

Artikel Nr. <i>Part no.</i>	Gesamt Ø <i>Total Ø</i>	Loch Ø <i>Hole Ø</i>	Kabel Ø <i>Cable Ø</i>	Spalt <i>Gap</i>	Gesamthöhe <i>Total height</i>	Material <i>Material</i>	
	Ø1	Ø2	Ø3	h	H		
0999	5,8	4,0	1,0	1,5	5,2	EB	
1001	7,8	5,0	3,0	1,4	5,0	EB	
1006	10,1	7,0	3,0	1,5	5,8	EB	
1009	9,0	6,0	4,5	1,0	4,0	EB	
1010	12,5	10,0	5,5	2,0	8,5	EB	
1012	15,5	9,5	5,5	0,8	5,0	EB	
1013	14,0	10,0	6,8	4,5	10,3	EB	

Information:

EB = EPDM, schwarz

Toleranzen nach (DIN ISO 3302, Teil 2 M2F)
Irrtum vorbehalten

Information:

EB = EPDM, black

General measuring tolerances (DIN ISO 3302, section 2 M2F)
Errors excepted



KABELDURCHFÜHRUNGEN MIT RADIUS CABLE GROMMETS WITH RADIUS

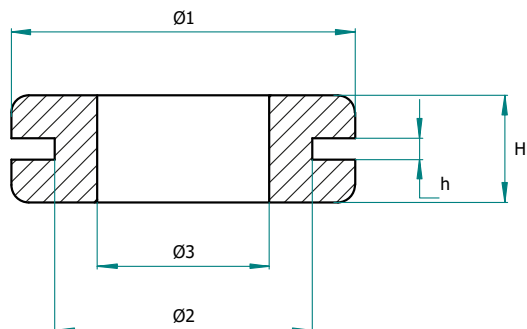

Artikel Nr. <i>Part no.</i>	Gesamt Ø <i>Total Ø</i>	Loch Ø <i>Hole Ø</i>	Kabel Ø <i>Cable Ø</i>	Spalt <i>Gap</i>	Gesamthöhe <i>Total height</i>	Material <i>Material</i>	
	Ø1	Ø2	Ø3	h	H		
1014	12,7	10,0	6,0	2,1	8,0	EB	
1015	16,0	12,0	6,8	1,5	8,0	EB	
1016	13,0	10,0	7,0	1,5	7,3	EB	
1021	9,5	6,5	4,5	1,2	6,0	EB	
1023	10,8	8,0	5,4	1,1	4,3	EB	
1024	11,0	7,0	4,4	2,0	7,0	EB	
1026	29,0	24,0	15,0	2,2	10,2	EB	

Information:

EB = EPDM, schwarz

Toleranzen nach (DIN ISO 3302, Teil 2 M2F)
Irrtum vorbehalten

Information:

EB = EPDM, black

General measuring tolerances (DIN ISO 3302, section 2 M2F)
Errors excepted



KABELDURCHFÜHRUNGEN MIT RADIUS CABLE GROMMETS WITH RADIUS

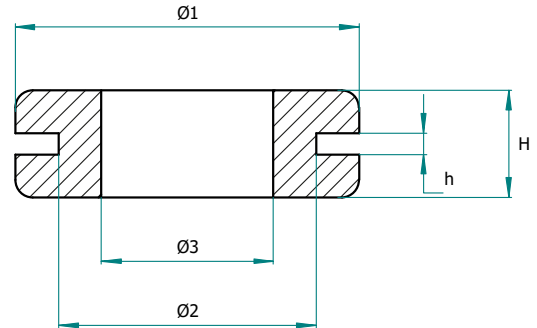

Artikel Nr. <i>Part no.</i>	Gesamt Ø <i>Total Ø</i>	Loch Ø <i>Hole Ø</i>	Kabel Ø <i>Cable Ø</i>	Spalt <i>Gap</i>	Gesamthöhe <i>Total height</i>	Material <i>Material</i>	
	Ø1	Ø2	Ø3	h	H		
1031	7,7	5,0	2,0	2,0	5,2	EB	
1037	12,0	8,4	5,8	2,5	8,8	EB	
1040	24,8	18,7	11,7	1,3	7,5	EB	
1051	9,3	6,2	4,0	3,0	6,0	EB	
1053	14,3	9,8	8,0	2,0	7,8	EB	
1054	12,2	9,3	5,8	1,5	7,0	EB	
1067	17,2	13,0	9,5	1,5	8,0	EB	

Information:

EB = EPDM, schwarz

Toleranzen nach (DIN ISO 3302, Teil 2 M2F)
Irrtum vorbehalten

Information:

EB = EPDM, black

General measuring tolerances (DIN ISO 3302, section 2 M2F)
Errors excepted



KABELDURCHFÜHRUNGEN MIT RADIUS CABLE GROMMETS WITH RADIUS

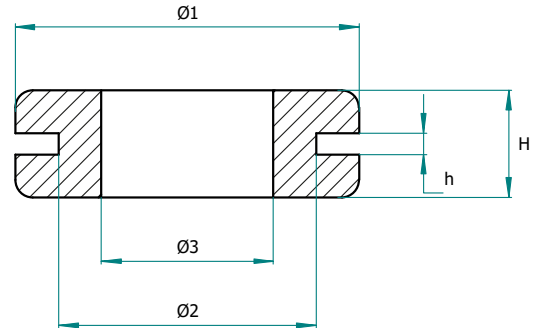

Artikel Nr. <i>Part no.</i>	Gesamt Ø <i>Total Ø</i>	Loch Ø <i>Hole Ø</i>	Kabel Ø <i>Cable Ø</i>	Spalt <i>Gap</i>	Gesamthöhe <i>Total height</i>	Material <i>Material</i>	
	Ø1	Ø2	Ø3	h	H		
1072	10,5	7,8	5,8	4,1	7,0	EB	
1078	7,7	5,0	3,0	1,0	4,4	EB	
1079	12,0	9,0	4,5	1,0	5,2	EB	
1082	11,2	8,0	6,0	1,0	6,2	EB	
1083	15,0	11,7	8,0	2,0	7,0	EB	

Information:

EB = EPDM, schwarz

Toleranzen nach (DIN ISO 3302, Teil 2 M2F)
Irrtum vorbehalten

Information:

EB = EPDM, black

General measuring tolerances (DIN ISO 3302, section 2 M2F)
Errors excepted



KABELDURCHFÜHRUNGEN OHNE RADIUS CABLE GROMMETS WITHOUT RADIUS

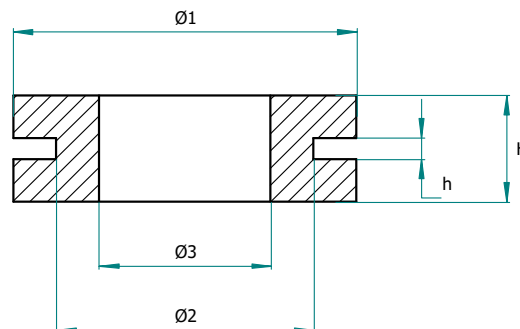

Artikel Nr. Part no.	Gesamt Ø Total Ø	Loch Ø Hole Ø	Kabel Ø Cable Ø	Spalt Gap	Gesamthöhe Total height	Material Material	
	Ø1	Ø2	Ø3	h	H		
0980	6,0	4,0	2,7	1,0	4,0	EB	
1007	11,0	7,0	4,5	3,0	6,5	EB	
1017	16,2	11,6	8,2	1,5	7,0	EB	
1038	15,0	10,0	6,0	2,0	6,5	EB	
1056	9,0	6,0	4,0	2,0	6,2	EB	
1063	6,0	4,3	1,6	0,5	3,0	EB	
1064	9,0	6,0	3,6	1,0	5,0	EB	

Information:

EB = EPDM, schwarz

Toleranzen nach (DIN ISO 3302, Teil 2 M2F)
Irrtum vorbehalten

Information:

EB = EPDM, black

General measuring tolerances (DIN ISO 3302, section 2 M2F)
Errors excepted



KABELDURCHFÜHRUNGEN OHNE RADIUS CABLE GROMMETS WITHOUT RADIUS

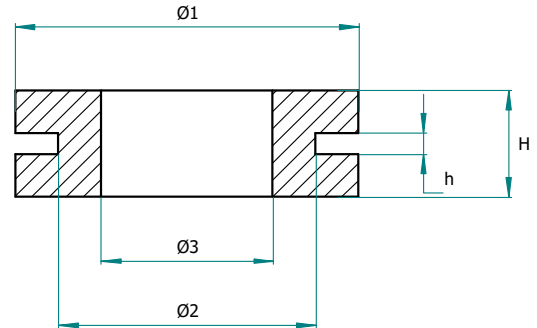

Artikel Nr. Part no.	Gesamt Ø Total Ø	Loch Ø Hole Ø	Kabel Ø Cable Ø	Spalt Gap	Gesamthöhe Total height	Material Material	
	Ø1	Ø2	Ø3	h	H		
1073	10,8	8,0	3,9	1,6	7,0	EB	
1075	13,0	10,0	6,0	2,2	5,5	EB	
1076	9,0	6,0	3,8	1,5	7,5	EB	
1080	6,0	4,3	2,5	0,6	3,0	EB	
1081	9,5	7,5	4,9	2,0	5,5	EB	
1084	5,0	3,7	2,5	1,2	4,0	EB	

Information:

EB = EPDM, schwarz

Toleranzen nach (DIN ISO 3302, Teil 2 M2F)
Irrtum vorbehalten

Information:

EB = EPDM, black

General measuring tolerances (DIN ISO 3302, section 2 M2F)
Errors excepted



KABELDURCHFÜHRUNGEN SONDERFORMEN CABLE GROMMETS SPECIAL FORM

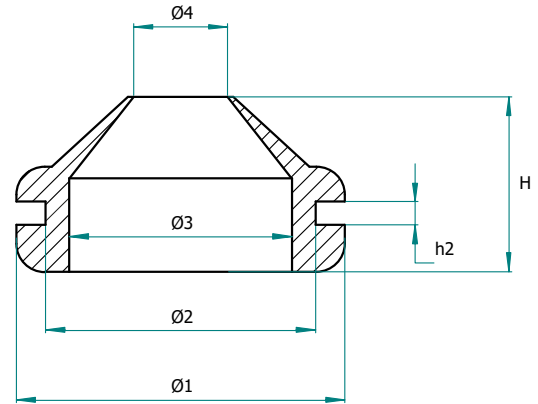

Artikel Nr. <i>Part no.</i>	Gesamt Ø <i>Total Ø</i>	Loch Ø <i>Hole Ø</i>	Innen Ø <i>Inner Ø</i>	Ø4 <i>Ø4</i>	Gesamthöhe <i>Total height</i>	Spalt <i>Gap</i>	Material <i>Material</i>	
	Ø1	Ø2	Ø3	Ø4	H	h2		
1020	19,7	15,0	11,6	6,5	10,0	2,0	EB	
1029 ¹⁾	24,5	19,0	14,5	9,0	14,5	2,5	EB	
1030	24,5	19,8	14,5	8,8	14,5	3,5	EB	

Information:

EB = EPDM, schwarz

1) = mit variablem Klemmbereich von 1,5 - 2,5mm

Toleranzen nach (DIN ISO 3302, Teil 2 M2F)

Irrtum vorbehalten

Information:

EB = EPDM, black

1) = with a variable clamping range of 1.5 – 2.5 mm

General measuring tolerances (DIN ISO 3302, section 2 M2F)

Errors excepted



KABELDURCHFÜHRUNGEN U-FORM CABLE GROMMETS U-SHAPE

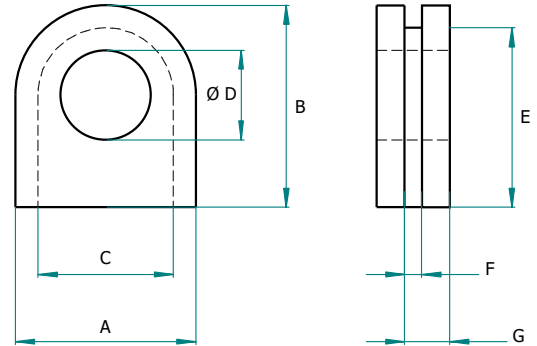

Artikel Nr. Part no.	Breite Width	Höhe Height	Aussparungsbreite Recess width	Kabel Ø Cable Ø	Aussparungshöhe Recess height	Spaltmaß Clearance	Einbautiefe Installation depth	Material Material	
	A	B	C	Ø D	E	F	G		
1033 ¹⁾	19,0	19,0	13,8	9,3	16,3	2,0	4,5	EB	
1048 ²⁾	13,8	13,8	10,5	7,0	12,0	1,5	3,5	EB	
1049 ³⁾	19,0	19,0	13,8	9,3	16,3	2,0	4,5	EB	
1059	13,8	13,8	10,5	7,0	12,0	1,5	3,5	EB	

Information:

EB = EPDM, schwarz

1) = mit innenliegender Membran. ; 2) = mit vorgelochter Membran

1mm Ø. ; 3) = mit vorgelochter Membran 2mm Ø.

Toleranzen nach (DIN ISO 3302, Teil 2 M2F)

Information:

EB = EPDM, black

1) = With inner membrane. ; 2) = Perforated membrane 1mm

Ø ; 3) = Perforated membrane 2mm Ø

General measuring tolerances (DIN ISO 3302, section 2 M2F)



KNICKSCHUTZTÜLLEN
BEND RELIEF GROMMETS

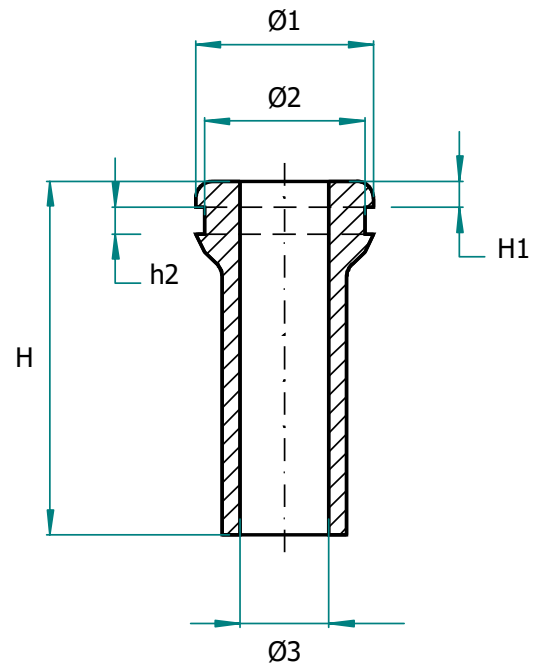

Artikel Nr. <i>Part no.</i>	Gesamt Ø <i>Total Ø</i>	Loch Ø <i>Hole Ø</i>	Kabel Ø <i>Cable Ø</i>	Bundhöhe <i>Collar height</i>	Spalt <i>Gap</i>	Gesamthöhe <i>Total height</i>	Material <i>Material</i>	
	Ø1	Ø2	Ø3	H1	h2	H		
0970	5,4	3,5	1,7	1,0	1,5	8,6	EB	
0998	6,8	5,0	3,0	2,1	2,0	18,0	EB	
1066	9,1	6,8	3,5	2,1	1,5	14,7	EB	

Information:

EB = EPDM, schwarz

Toleranzen nach (DIN ISO 3302, Teil 2 M2F)
Irrtum vorbehalten

Information:

EB = EPDM, black

General measuring tolerances (DIN ISO 3302, section 2 M2F)
Errors excepted



LANGLOCHTÜLLE OBLONG GROMMET

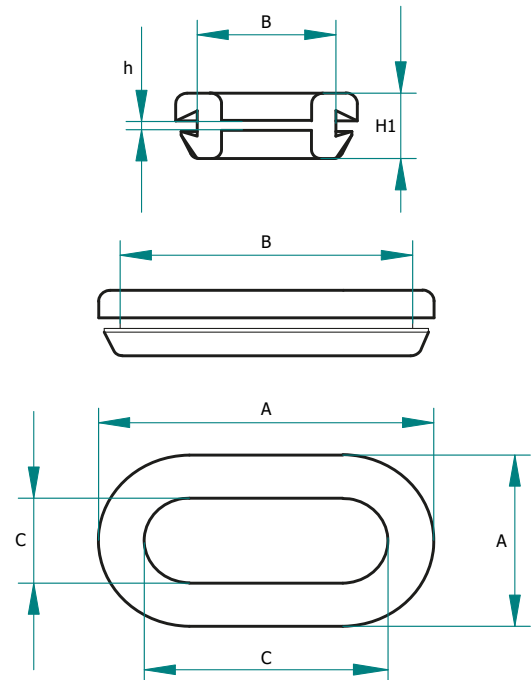

Artikel Nr. Part no.	Außenmaße Total dimensions	Einbaumaße Installation dimensions	Innenmaße Inner dimensions	Klemmbereich Gap	Gesamthöhe Total height	Membrandicke Membrane thickness	Material Material	
	A	B	C	h	H1	M		
1027 ¹⁾	35,0 x 17,0	30,0 x 12,0	26,6 x 8,3	2,8	6,3	1,0	EB	
1028 ²⁾	35,0 x 17,0	30,0 x 12,0	26,6 x 8,3	2,8	6,3	1,0	EB	
1097	29,0 x 16,0	25,0 x 12,0	21,0 x 8,0	1 - 2,5	6,0	0,8	EB	
1098	42,0 x 19,0	37,0 x 14,0	33,0 x 10,0	1 - 2,5	7,0	0,8	EB	
1099	58,0 x 24,0	50,0 x 16,0	46,0 x 12,0	1 - 2,5	9,0	1,0	EB	
1196	24,5 x 14,7	20,0 x 10,0	16,5 x 6,5	1 - 2,5	6,5	0,8	EB	 COMING SOON

Information:

EB = EPDM, schwarz

1) = mit Lochung (Durchmesserzeichen) 5,5 mm (9 mm außermittig, links) und Lochvorprägung (Durchmesserzeichen) 3 mm (2 mm aussermittig, rechts) ; 2) = mit aussenliegender Membran

Information:

EB = EPDM, black

1) = with perforation (diameter mark) 5.5 mm (9 mm off-centre, left) and hole pre-embossing (diameter mark) 3 mm (2 mm off-centre, right) ; 2) = with outer membrane



SNAP[®] EASY TIGHT
SNAP[®] EASY-TIGHT

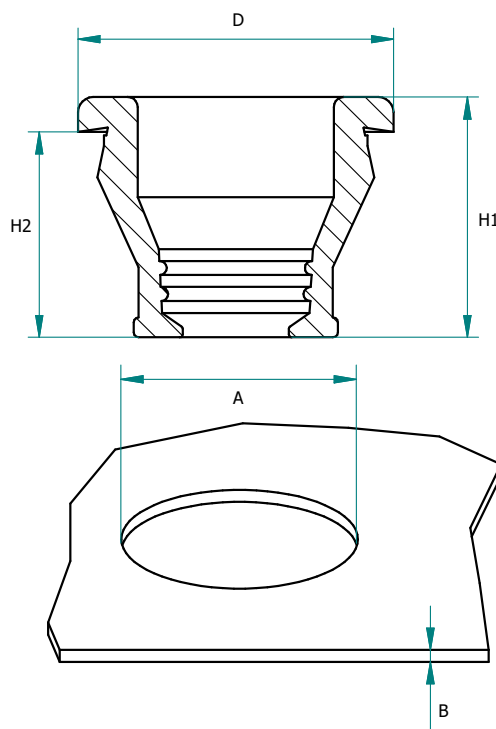

Artikel Nr. Part no.	Nennmaß Nominal size	Kabel Ø Cable Ø	Loch Ø Panel hole size	Wandstärke Panel thickness	Gesamt Ø Total Ø	Gesamthöhe Total height	Einbautiefe Installation depth	Material Material	
			A	B	D	H1	H2		
1490	M 10	1,5 - 4,0	10,5	1 - 4,0	14,0	18,5	15,0	EB	
1491	M 12 / PG 7	4 - 6	12,5	1 - 4,0	16,0	20,5	17,0	EB	
1492	M 16 / PG 9	6 - 9	16,5	1 - 4,0	21,0	22,0	18,5	EB	
1493	M 20	9 - 12	20,5	1 - 4,0	25,5	22,0	18,5	EB	
1494	M 25	12 - 16	25,5	1 - 4,0	31,5	24,0	20,5	EB	
1495	M 32	16 - 20	32,5	1 - 6,0	38,0	27,5	23,5	EB	
1496	M 40	20 - 26	40,5	1 - 6,0	46,5	28,5	24,5	EB	

Information:

EB = EPDM, schwarz

Toleranzen nach (DIN ISO 3302, Teil 2 M2F)
Irrtum vorbehalten

Information:

EB = EPDM, black

General measuring tolerances (DIN ISO 3302, section 2 M2F)
Errors excepted



SNAP[®] EASY TIGHT
SNAP[®] EASY-TIGHT

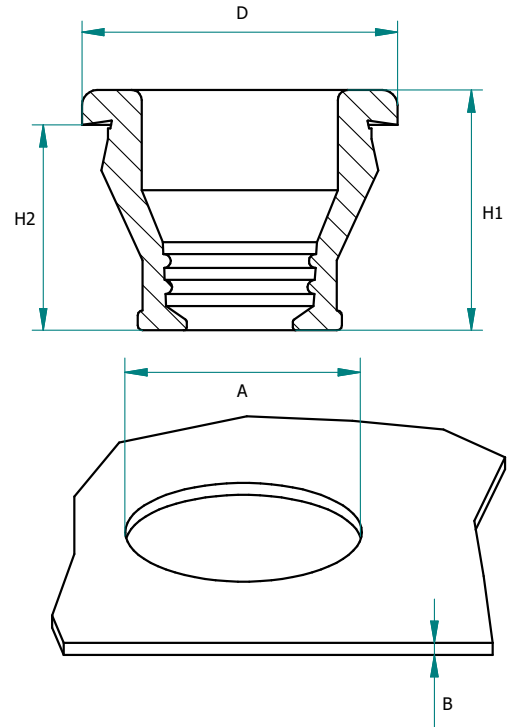

Artikel Nr. <i>Part no.</i>	Nennmaß <i>Nominal size</i>	Kabel Ø <i>Cable Ø</i>	Loch Ø <i>Panel hole size</i>	Wandstärke <i>Panel thickness</i>	Gesamt Ø <i>Total Ø</i>	Gesamthöhe <i>Total height</i>	Einbautiefe <i>Installation depth</i>	Material <i>Material</i>	
			A	B	D	H1	H2		
1497	M 50	26 - 35	50,5	1 - 6,0	58,0	30,0	25,5	EB	

Information:

EB = EPDM, schwarz

Toleranzen nach (DIN ISO 3302, Teil 2 M2F)
Irrtum vorbehalten

Information:

EB = EPDM, black

General measuring tolerances (DIN ISO 3302, section 2 M2F)
Errors excepted



SNAP[®] METRIC LIGHT
SNAP[®] METRIC LIGHT

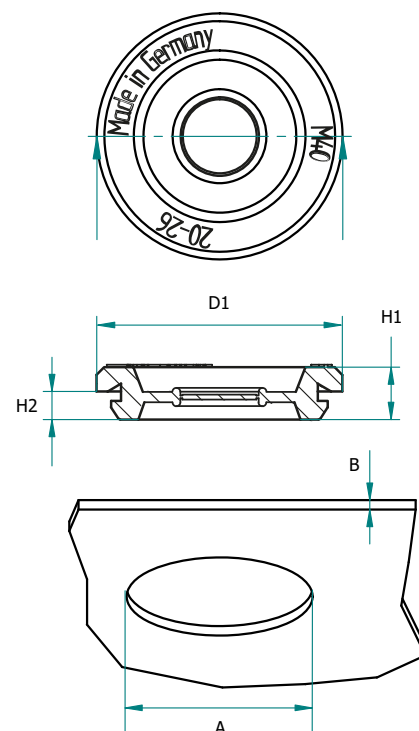

Artikel Nr. <i>Part no.</i>	Nennmaß <i>Nominal size</i>	Kabel Ø <i>Cable Ø</i>	Loch Ø <i>Panel hole size</i>	Wandstärke <i>Panel thickness</i>	Gesamt Ø <i>Total Ø</i>	Innen Ø <i>Inner Ø</i>	Gesamthöhe <i>Total height</i>	Einbautiefe <i>Installation depth</i>	Material <i>Material</i>	
			A	B	Ø D1	Ø D2	H1	H2		
1600	M 12 / PG 7	3 - 5	12,5	1 - 2,5	18,5	-	7,5	2,5	EB, SB	
1601	M 16 / PG 9	5 - 7	16,5	1 - 2,5	22,5	-	7,5	2,5	EB, SB	
1602	M 20	7 - 10	20,5	1 - 2,5	26,5	-	7,5	2,5	EB, SB	
1603	M 25	10 - 14	25,5	1 - 2,5	31,5	-	7,5	2,5	EB, SB	
1604	M 32	14 - 20	32,5	1 - 2,5	39,0	-	9,0	3,0	EB, SB	
1605	M 40	20 - 26	40,5	1 - 3,5	49,0	-	10,5	3,5	EB, SB	
1606	M 50	26 - 35	50,5	1 - 3,5	58,5	-	11,0	4,0	EB, SB	

Information:

EB = EPDM, schwarz ; SB = Silikon, schwarz

Toleranzen nach (DIN ISO 3302, Teil 2 M2F)
Irrtum vorbehalten

Information:

EB = EPDM, black ; SB = Silicon, black

General measuring tolerances (DIN ISO 3302, section 2 M2F)
Errors excepted



SNAP[®] METRIC LIGHT
SNAP[®] METRIC LIGHT

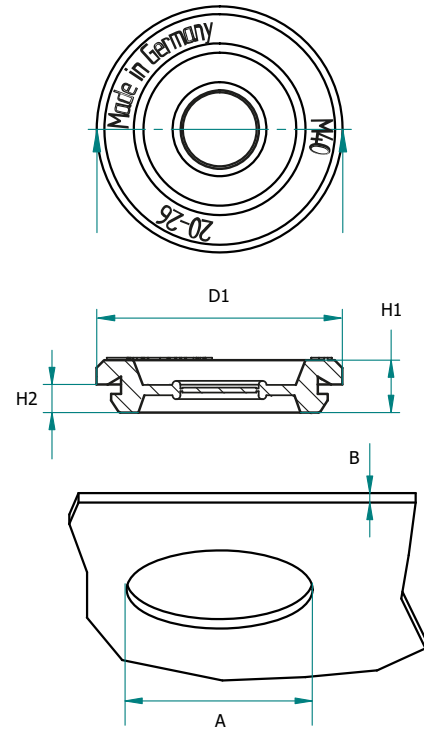

Artikel Nr. <i>Part no.</i>	Nennmaß <i>Nominal size</i>	Kabel Ø <i>Cable Ø</i>	Loch Ø <i>Panel hole size</i>	Wandstärke <i>Panel thickness</i>	Gesamt Ø <i>Total Ø</i>	Innen Ø <i>Inner Ø</i>	Gesamthöhe <i>Total height</i>	Einbautiefe <i>Installation depth</i>	Material <i>Material</i>
			A	B	Ø D1	Ø D2	H1	H2	
1607	M 63	35 - 40	63,5	1 - 3,5	71,5	-	11,5	4,5	EB, SB



Information:

EB = EPDM, schwarz ; SB = Silikon, schwarz

Toleranzen nach (DIN ISO 3302, Teil 2 M2F)
Irrtum vorbehalten

Information:

EB = EPDM, black ; SB = Silicon, black

General measuring tolerances (DIN ISO 3302, section 2 M2F)
Errors excepted



SNAP[®] METRIC LIGHT OPEN
SNAP[®] METRIC LIGHT OPEN

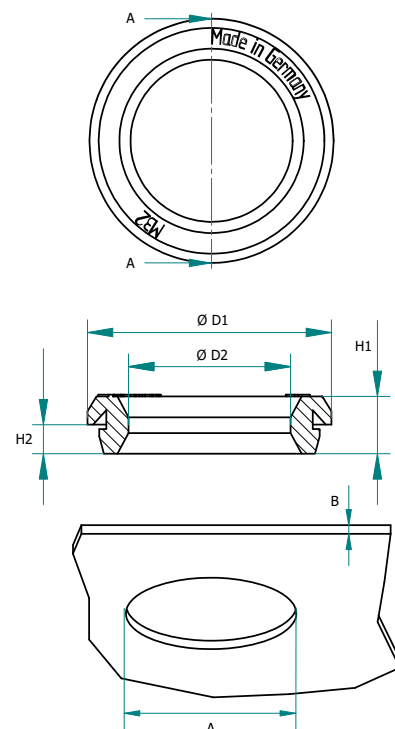

Artikel Nr. Part no.	Nennmaß Nominal size	Kabel Ø Cable Ø	Loch Ø Panel hole size	Wandstärke Panel thickness	Gesamt Ø Total Ø	Innen Ø Inner Ø	Gesamthöhe Total height	Einbautiefe Installation depth	Material Material	
			A	B	Ø D1	Ø D2	H1	H2		
3000	M 12 / PG 7	0 - 9,0	12,5	1 - 2,5	18,5	9,0	7,5	2,5	EB	
3001	M 16 / PG 9	0 - 12,0	16,5	1 - 2,5	22,5	12,0	7,5	2,5	EB	
3002	M 20	0 - 16,0	20,5	1 - 2,5	26,5	16,0	7,5	2,5	EB	
3003	M 25	0 - 20,0	25,5	1 - 2,5	31,5	20,0	7,5	2,5	EB	
3004	M 32	0 - 25,5	32,5	1 - 2,5	39,0	25,5	9,0	3,0	EB	
3005	M 40	0 - 32,0	40,5	1 - 3,5	49,0	32,0	10,5	3,5	EB	
3006	M 50	0 - 41,0	50,5	1 - 3,5	58,5	41,0	11,0	4,0	EB	

Information:

EB = EPDM, schwarz

Toleranzen nach (DIN ISO 3302, Teil 2 M2F)
Irrtum vorbehalten

Information:

EB = EPDM, black

General measuring tolerances (DIN ISO 3302, section 2 M2F)
Errors excepted



SNAP[®] METRIC LIGHT OPEN
SNAP[®] METRIC LIGHT OPEN

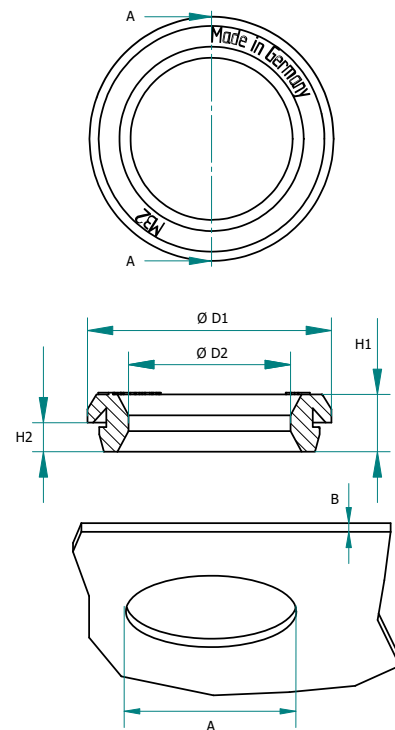

Artikel Nr. <i>Part no.</i>	Nennmaß <i>Nominal size</i>	Kabel Ø <i>Cable Ø</i>	Loch Ø <i>Panel hole size</i>	Wandstärke <i>Panel thickness</i>	Gesamt Ø <i>Total Ø</i>	Innen Ø <i>Inner Ø</i>	Gesamthöhe <i>Total height</i>	Einbautiefe <i>Installation depth</i>	Material <i>Material</i>	
			A	B	Ø D1	Ø D2	H1	H2	EB	
3007	M 63	0 - 53,0	63,5	1 - 3,5	71,5	53,0	11,5	4,5	EB	

Information:

EB = EPDM, schwarz

Toleranzen nach (DIN ISO 3302, Teil 2 M2F)
Irrtum vorbehalten

Information:

EB = EPDM, black

General measuring tolerances (DIN ISO 3302, section 2 M2F)
Errors excepted



SNAP® PG
SNAP® PG

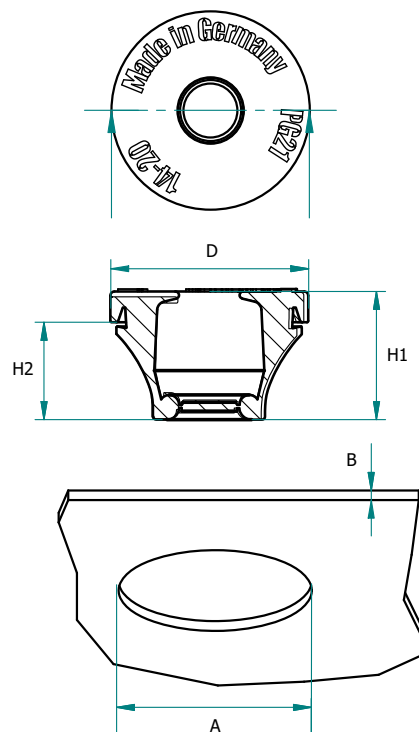

Artikel Nr. Part no.	Nennmaß Nominal size	Kabel Ø Cable Ø	Loch Ø Panel hole size	Wandstärke Panel thickness	Gesamt Ø Total Ø	Gesamthöhe Total height		Material Material	
			A	B		D	H1		
1102	PG 11	7 - 10	19,0	1,0 - 4,0	24,0	19,5	13,5	EG, EB, CB, SB	
1103	PG 16	10 - 14	23,0	1,0 - 4,0	28,0	22,5	16,0	EG, EB, CB, SB	
1104	PG 21	14 - 20	29,0	1,0 - 4,0	35,0	24,5	17,5	EG, EB, CB, SB	
1105	PG 29	20 - 26	38,0	1,0 - 4,0	46,0	30,0	21,0	EG, EB, CB, SB	
1106	PG 36	26 - 35	48,0	1,0 - 4,0	58,0	35,0	25,0	EG, EB, CB, SB	
1200	M 12 / PG 7	3 - 5	12,5	1,0 - 4,0	18,5	17,0	10,5	EG, EB, CB, SB	
1201	M 16 / PG 9	5 - 7	16,5	1,0 - 4,0	21,5	19,0	12,0	EG, EB, CB, SB	

Information:

EG = EPDM, grau ; EB = EPDM, schwarz ; CB = CR, schwarz ; SB = Silikon, schwarz

IP66 / IP67, fachgerechte Montage vorausgesetzt
Toleranzen nach (DIN ISO 3302, Teil 2 M2F)

Information:

EG = EPDM, gray ; EB = EPDM, black ; CB = CR, black ; SB = Silicon, black

IP66 / IP67
General measuring tolerances (DIN ISO 3302, section 2 M2F)



SNAP® PG OPEN
SNAP® PG OPEN

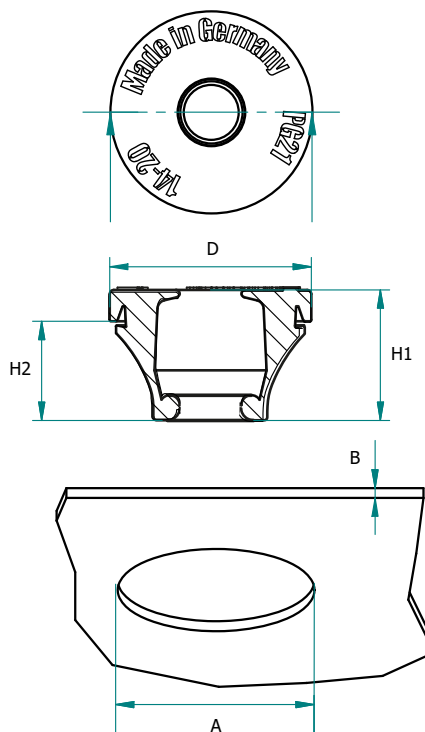

Artikel Nr. Part no.	Nennmaß Nominal size	Kabel Ø Cable Ø	Loch Ø Panel hole size	Wandstärke Panel thickness	Gesamt Ø Total Ø	Gesamthöhe Total height		Material Material	
			A	B		D	H1		
1112	PG 11	7 - 10	19,0	1,0 - 4,0	24,0	19,5	13,5	EG, EB, SB	
1113	PG 16	10 - 14	23,0	1,0 - 4,0	28,0	22,5	16,0	EG, EB, SB	
1114	PG 21	14 - 20	29,0	1,0 - 4,0	35,0	24,5	17,5	EG, EB, SB	
1115	PG 29	20 - 26	38,0	1,0 - 4,0	46,0	30,0	21,0	EG, EB, SB	
1116	PG 36	26 - 35	48,0	1,0 - 4,0	58,0	35,0	25,0	EG, EB, SB	
1210 ¹⁾	M 12 / PG 7	3 - 5	12,5	1,0 - 4,0	18,5	17,0	10,5	EG, EB, SB	
1211	M 16 / PG 9	5 - 7	16,5	1,0 - 4,0	21,5	19,0	12,0	EG, EB, SB	

Information:

EG = EPDM, grau ; EB = EPDM, schwarz ; SB = Silikon, schwarz
1) = IP66 / IP67, fachgerechte Montage vorausgesetzt
Toleranzen nach (DIN ISO 3302, Teil 2 M2F)
Irrtum vorbehalten

Information:

EG = EPDM, gray ; EB = EPDM, black ; SB = Silicon, black
1) = IP66 / IP67
General measuring tolerances (DIN ISO 3302, section 2 M2F)
Errors excepted



SNAP[®] METRIC
SNAP[®] METRIC

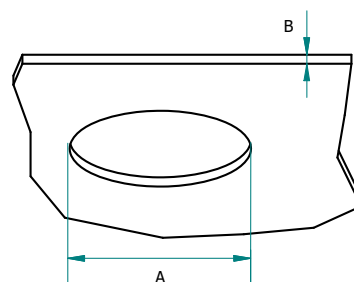
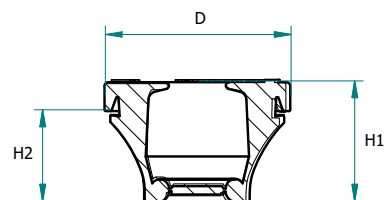
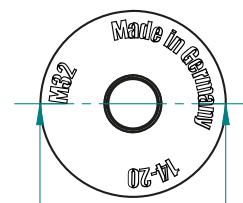

Artikel Nr. Part no.	Nennmaß Nominal size	Kabel Ø Cable Ø	Loch Ø Panel hole size	Wandstärke Panel thickness	Gesamt Ø Total Ø	Gesamthöhe Total height		Material Material	
			A	B	D	H1	H2		
1200	M 12 / PG 7	3 - 5	12,5	1,0 - 4,0	18,5	17,0	10,5	EG, EB, CB, SB	
1201	M 16 / PG 9	5 - 7	16,5	1,0 - 4,0	21,5	19,0	12,0	EG, EB, CB, SB	
1202	M 20	7 - 10	20,5	1,0 - 4,0	25,5	20,5	14,0	EG, EB, CB, SB	
1203	M 25	10 - 14	25,5	1,0 - 4,0	30,5	23,0	15,5	EG, EB, CB, SB	
1204	M 32	14 - 20	32,5	1,0 - 4,0	38,5	25,0	18,0	EG, EB, CB, SB	
1205	M 40	20 - 26	40,5	1,0 - 4,0	49,0	32,0	22,0	EG, EB, CB, SB	
1206	M 50	26 - 35	50,5	1,0 - 4,0	60,5	37,5	25,5	EG, EB, CB, SB	

Information:

EG = EPDM, grau ; EB = EPDM, schwarz ; CB = CR, schwarz ; SB = Silikon, schwarz

IP66 / IP67, fachgerechte Montage vorausgesetzt
Toleranzen nach (DIN ISO 3302, Teil 2 M2F)

Information:

EG = EPDM, gray ; EB = EPDM, black ; CB = CR, black ; SB = Silicon, black

IP66 / IP67
General measuring tolerances (DIN ISO 3302, section 2 M2F)



SNAP[®] METRIC OPEN
SNAP[®] METRIC OPEN

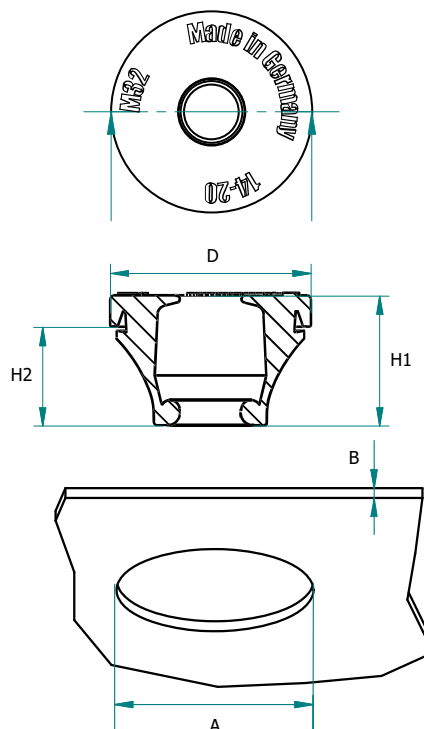

Artikel Nr. Part no.	Nennmaß Nominal size	Kabel Ø Cable Ø	Loch Ø Panel hole size	Wandstärke Panel thickness	Gesamt Ø Total Ø	Gesamthöhe Total height		Material Material	
			A	B		D	H1		
1210 ¹⁾	M12 / PG 7	3 - 5	12,5	1,0 - 4,0	18,5	17,0	10,5	EG, EB, SB	
1211	M 16 / PG 9	5 - 7	16,5	1,0 - 4,0	21,5	19,0	12,0	EG, EB, SB	
1212	M 20	7 - 10	20,5	1,0 - 4,0	25,5	20,5	14,0	EG, EB, SB	
1213	M 25	10 - 14	25,5	1,0 - 4,0	30,5	23,0	15,5	EG, EB, SB	
1214	M 32	14 - 20	32,5	1,0 - 4,0	38,5	25,0	18,0	EG, EB, SB	
1215	M 40	20 - 26	40,5	1,0 - 4,0	49,0	32,0	22,0	EG, EB, SB	
1216	M 50	26 - 35	50,5	1,0 - 4,0	60,5	37,5	25,5	EG, EB, SB	

Information:

EG = EPDM, grau ; EB = EPDM, schwarz ; SB = Silikon, schwarz
1) = IP66 / IP67, fachgerechte Montage vorausgesetzt
Toleranzen nach (DIN ISO 3302, Teil 2 M2F)
Irrtum vorbehalten

Information:

EG = EPDM, gray ; EB = EPDM, black ; SB = Silicon, black
1) = IP66 / IP67
General measuring tolerances (DIN ISO 3302, section 2 M2F)
Errors excepted



SNAP[®] MULTIFLEX
SNAP[®] MULTIFLEX

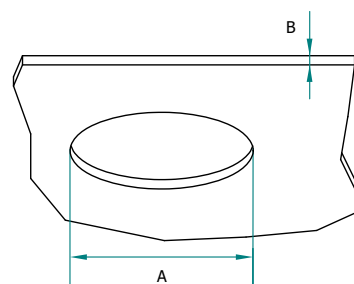
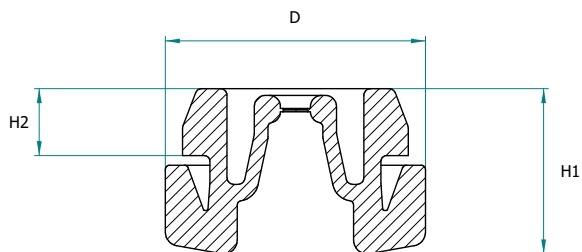

Artikel Nr. Part no.	Nennmaß Nominal size	Loch Ø Panel hole size	Wandstärke Panel thickness	Kabel Ø Cable Ø	Gesamt Ø Total Ø	Gesamthöhe Total height	Höhe Height	Material Material	
		A	B		D	H1	H2		
4000	M 12 / PG 7	12,5	1 - 4,0	2 - 6	19,0	12,0	5,0	EG, SB, EB	
4001	M 16 / PG 9	16,5	1 - 4,0	5 - 8	22,0	12,0	5,0	EG, SB, EB	
4002	M 20	20,5	1 - 4,0	7 - 12	27,0	12,50	5,0	EG, SB, EB	COMING SOON
4003	M 25	25,5	1 - 4,0	8 - 16	33,0	12,70	5,0	EG, SB, EB	COMING SOON

Information:

EG = EPDM, grau ; SB = Silikon, schwarz ; EB = EPDM, schwarz
IP66 / IP67, fachgerechte Montage vorausgesetzt
Toleranzen nach (DIN ISO 3302, Teil 2 M2F)
Irrtum vorbehalten

Information:

EG = EPDM, gray ; SB = Silicon, black ; EB = EPDM, black
IP66/67
General measuring tolerances (DIN ISO 3302, section 2 M2F)
Errors excepted



SNAP[®] MULTIGATE
SNAP[®] MULTIGATE

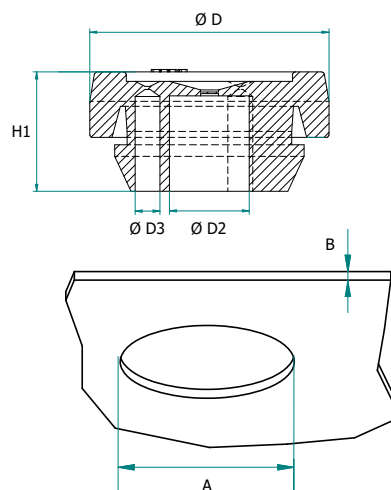
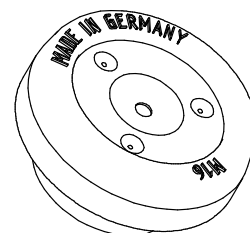

Artikel Nr. Part no.	Nennmaß Nominal size	Loch Ø Panel hole size	Wandstärke Panel thickness	Gesamt Ø Total Ø	Innen Ø Inner Ø	Innen Ø / (Kabel Ø) Inner Ø / (Cable Ø)	Gesamthöhe Total height	Innen Ø Inner Ø	Innen Ø / (Kabel Ø) Inner Ø / (Cable Ø)	Material Material	
		A	B	D	Ø D2		H1	Ø D3			
3100	M 16 / PG 9	16,5	1 - 4,0	24,0	1 x 8,0	1 x 8,0	12,0	3 x 2,5	3 x 2,5	EB, EG	
3101	M 20	20,5	1 - 4,0	27,5	-	3 x 8,0	12,0	-	-	EB, EG	
3102	M 25	25,5	1 - 4,0	32,5	-	4 x 8,0	12,0	-	-	EB, EG	
3103	M 32	32,5	1 - 4,0	41	-	4 x 11,0	12,75	-	-	EB, EG	

Information:

EB = EPDM, schwarz ; EG = EPDM, grau

Toleranzen nach (DIN ISO 3302, Teil 2 M2F)
Irrtum vorbehalten

Information:

EB = EPDM, black ; EG = EPDM, gray

General measuring tolerances (DIN ISO 3302, section 2 M2F)
Errors excepted



SNAP[®] - DNG
SNAP[®] - DNG

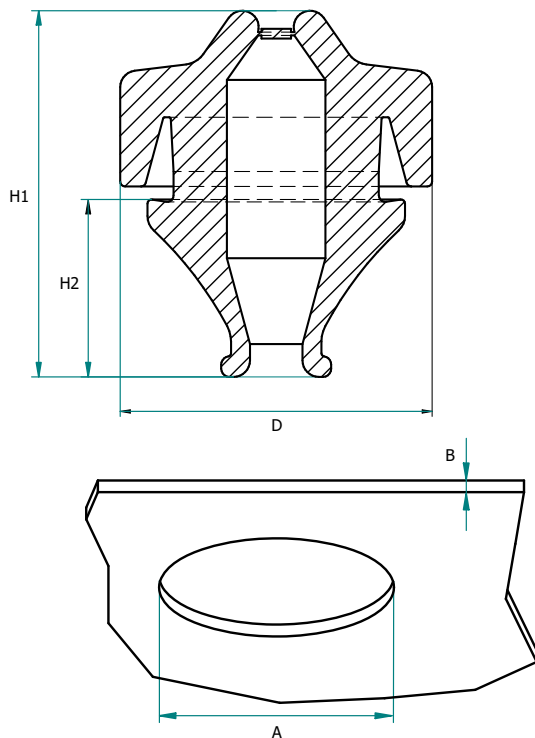

Artikel Nr. Part no.	Nennmaß Nominal size	Wandstärke Panel thickness	Loch Ø Panel hole size	Kabel Ø Cable Ø	Gesamt Ø Total Ø	Gesamthöhe Total height	Höhe Height	Material Material	
		B	A			H1			
4500	M 12 / PG 7	1,0 - 5,0	12,5	3,0 - 5,0	19,0	22,25	10,5	EG, EB	
4501	M 16 / PG 9	1,0 - 5,0	16,5	5,0 - 7,0	22,25	22,75	11,0	EG, EB	
4502	M20	1,0 - 5,0	20,5	7,0 - 10,0	27,0	24,25	12,5	EG, EB	
4503	M25	1,0 - 5,0	25,5	10,0 - 14,0	32,0	24,5	12,75	EG, EB	

Information:

EG = EPDM, grau ; EB = EPDM, schwarz
IP66 / IP67, fachgerechte Montage vorausgesetzt
Toleranzen nach (DIN ISO 3302, Teil 2 M2F)
Irrtum vorbehalten

Information:

EG = EPDM, gray ; EB = EPDM, black
IP66 / IP67
General measuring tolerances (DIN ISO 3302, section 2 M2F)
Errors excepted



KABELDURCHFÜHRUNGEN SONDERFORMEN CABLE GROMMETS SPECIAL FORM

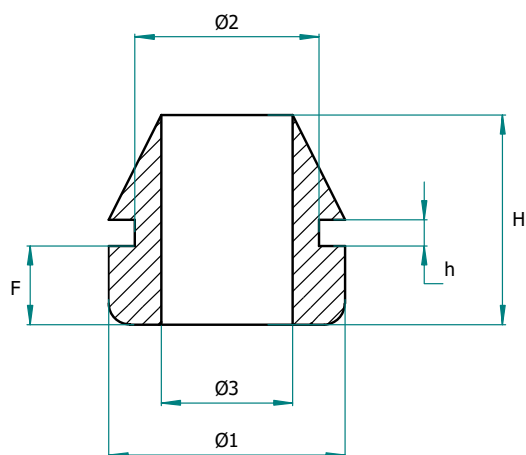

Artikel Nr. <i>Part no.</i>	Gesamt Ø <i>Total Ø</i>	Loch Ø <i>Hole Ø</i>	Kabel Ø <i>Cable Ø</i>	Spalt <i>Gap</i>	Gesamthöhe <i>Total height</i>	Kopfhöhe <i>Head height</i>	Material <i>Material</i>	
	Ø1	Ø2	Ø3	h	H	F		
0996	8,0	5,0	2,4	1,5	6,0	1,5	EB	
1002	10,0	7,0	5,0	1,5	6,7	1,5	EB	
1003	11,7	8,5	6,5	1,5	7,0	1,5	EB	
1089	11,7	9,8	6,8	1,0	8,2	3,5	EB	

Information:

EB = EPDM, schwarz

Toleranzen nach (DIN ISO 3302, Teil 2 M2F)
Irrtum vorbehalten

Information:



EB = EPDM, black

General measuring tolerances (DIN ISO 3302, section 2 M2F)
Errors excepted

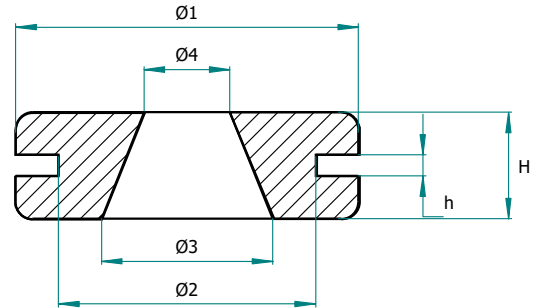

KABELDURCHFÜHRUNGEN MIT REDUZIERTEM DURCHGANG CABLE GROMMETS SPECIAL FORM



Artikel Nr. <i>Part no.</i>	Gesamt Ø <i>Total Ø</i>	Loch Ø <i>Hole Ø</i>	Ø3 <i>Ø3</i>	Ø4 <i>Ø4</i>	Gesamthöhe <i>Total height</i>	Spalt <i>Gap</i>	Material <i>Material</i>	
	Ø1	Ø2	Ø3	Ø4	H	h		
1044	15,0	11,0	8,0	7,0	7,0	2,0	EB	
1062	15,7	10,7	10,7	4,3	5,0	1,5	EB	

Information:

EB = EPDM, schwarz

Toleranzen nach (DIN ISO 3302, Teil 2 M2F)
Irrtum vorbehalten

Information:

EB = EPDM, black

General measuring tolerances (DIN ISO 3302, section 2 M2F)
Errors excepted



VERSCHLUSSTÜLLEN - FORM 1 SEALING (BLANKING) PLUG - SHAPE 1

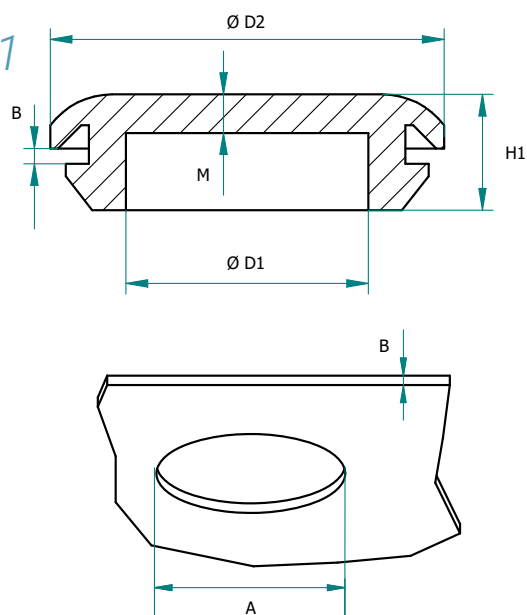

Artikel Nr. Part no.	Nennmaß Nominal size	Loch Ø Panel hole size	Wandstärke Panel thickness	Innen Ø Inner Ø	Gesamt Ø Total Ø	Gesamthöhe Total height	Membrandicke Membrane thickness	Material Material	
		A	B	Ø D1	Ø D2	H1	M		
1550	M 10	10,5	1 - 2,5	6,0	14,5	7,3	2,0	EB	
1551	M 12	12,5	1 - 2,5	8,0	17,5	7,3	2,0	EB	
1552	M 16	16,5	1 - 2,5	12,0	21,0	7,5	2,0	EB	
1553	M 20	20,5	1 - 2,5	15,5	26,0	7,7	2,5	EB	
1554	M 25	25,5	1 - 2,5	19,5	32,0	7,7	3,0	EB	
1555	M 32	32,5	1 - 2,5	24,5	39,0	7,5	3,0	EB	

Information:

EB = EPDM, schwarz

Toleranzen nach (DIN ISO 3302, Teil 2 M2F)
Irrtum vorbehalten

Information:

EB = EPDM, black

General measuring tolerances (DIN ISO 3302, section 2 M2F)
Errors excepted



VERSCHLUSSTÜLLEN - FORM 2
SEALING (BLANKING) PLUG - SHAPE 2

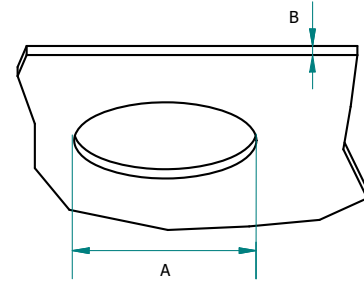
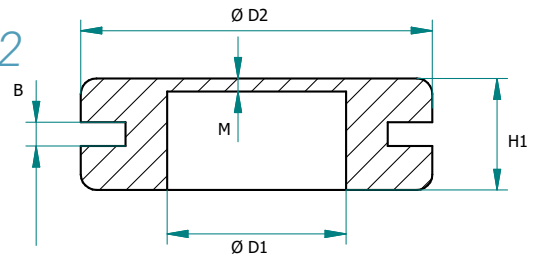
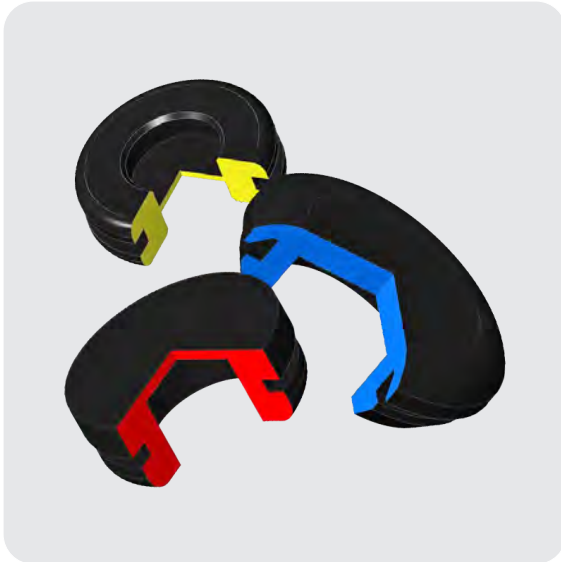

Artikel Nr. Part no.	Nennmaß Nominal size	Loch Ø Panel hole size	Wandstärke Panel thickness	Innen Ø Inner Ø	Gesamt Ø Total Ø	Gesamthöhe Total height	Membrandicke Membrane thickness	Material Material	
		A	B	Ø D1	Ø D2	H1	M		
1018	-	13,8	1,2	9,7	17,5	7,0	0,1	EB	
1052	-	10,0	3,0	5,9	13,0	7,2	0,9	EB	
1061	-	18,2	2,0	13,7	23,7	6,5	0,7	EB	
1070	-	16,0	2,8	12,0	21,0	6,6	1,4	EB	
1074	-	10,0	1,5	7,8	15,0	8,5	2,0	EB	

Information:

EB = EPDM, schwarz

Toleranzen nach (DIN ISO 3302, Teil 2 M2F)
Irrtum vorbehalten

Information:

EB = EPDM, black

General measuring tolerances (DIN ISO 3302, section 2 M2F)
Errors excepted



VERSCHLUSSTÜLLEN - FORM 3 SEALING (BLANKING) PLUG - SHAPE 3

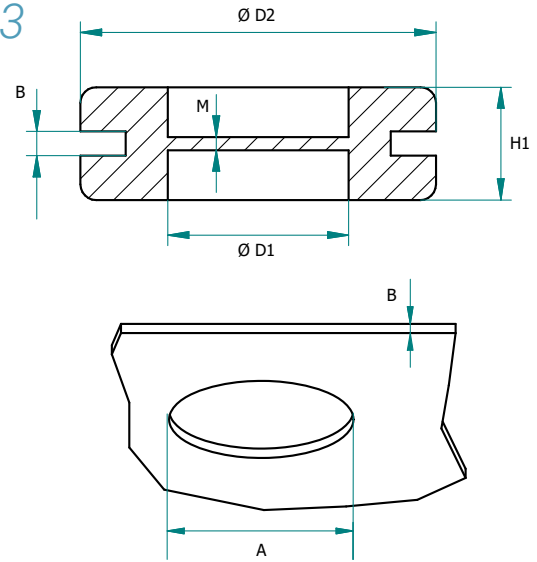
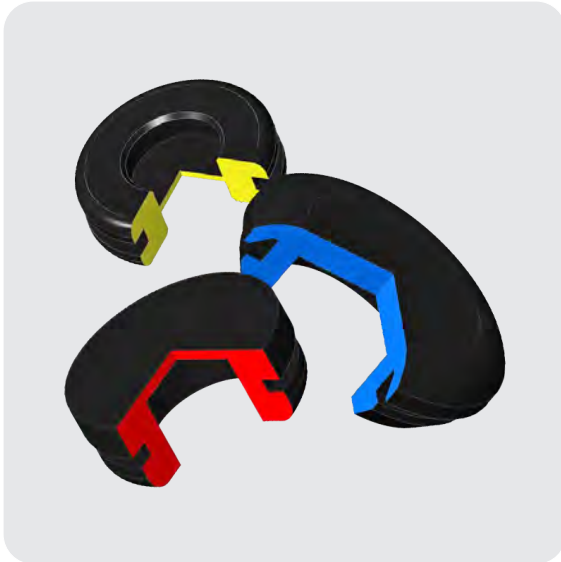

Artikel Nr. Part no.	Nennmaß Nominal size	Loch Ø Panel hole size	Wandstärke Panel thickness	Innen Ø Inner Ø	Gesamt Ø Total Ø	Gesamthöhe Total height	Membrandicke Membrane thickness	Material Material	
		A	B	Ø D1	Ø D2	H1	M		
1032	-	13,7	2,0	8,8	18,8	7,0	1,0	EB	
1034	-	18,5	1,7	11,0	23,0	7,0	0,8	EB	
1042	-	13,0	2,7	9,0	20,8	9,0	0,8	EB	
1060	-	13,0	1,5	9,5	17,3	8,0	0,6	EB	

Information:

EB = EPDM, schwarz

Toleranzen nach (DIN ISO 3302, Teil 2 M2F)
Irrtum vorbehalten

Information:

EB = EPDM, black

General measuring tolerances (DIN ISO 3302, section 2 M2F)
Errors excepted





A. Vogt GmbH & Co. KG

Weberstraße 7

D - 59757 Arnsberg

Germany

Fon +49 (2932) 9636-0

Fax +49 (2932) 9636-60

Mail info@gummivogt.de